

Voice Reversals and Syntactic Structure: Evidence from Hittite

Anthony D. Yates
University of California, Los Angeles
adyates@ucla.edu

John Gluckman
University of Kansas
johnglu@ku.edu

Abstract We address the relationship between syntactic valency and voice morphology in Hittite (Anatolian, Indo-European), focusing on cases where active syntax is expressed using non-active morphology, and *vice versa*. We argue that apparent “mismatches” between syntax and morphology are strictly a morphological rather than a syntactic phenomenon (*contra* Alexiadou et al. 2015; Grestenberger 2018). Our study highlights voice “reversals” — i.e., cases in which the expected mismatch disappears and morphological and syntactic valency match. We determine that such reversals correlate with morphological locality, and cannot be derived by hierarchical factors. Our findings provide a novel argument for a uniform syntactic structure of voice (Wood 2015; Wood & Marantz 2018).

Keywords: morphology; voice; deponency; Hittite; Indo-European

1 Introduction

The morphological expression of valency, i.e., *voice*, is of interest to syntacticians because it provides a window onto hierarchical structure. In general, the patterns seen in voice morphology can be directly mapped to syntactic trees. In such cases, it can be said that the morphology and the syntax are aligned. Verbs which are marked with “active” morphology have particular (perhaps language specific) syntactic properties, while verbs which are marked as “non-active” exhibit different syntactic behaviors (Embick 1998).

A phenomenon that has played an important role in the discussion of the relationship between voice morphology and syntax are cases of *voice mismatches*. These are contexts in which the morphology and syntax do not align. One such well-known case is *deponency*: non-active morphology appears on a transitive verb. Theories diverge on how to account for such misalignments. The crux of the debate hinges on whether such irregularities should be analyzed as truly exceptional properties of morphology (i.e., an idiosyncratic morphological quirk like English irregular past

tense morphology), or whether a “strict” mapping between syntax and morphology should be maintained. The latter proposal essentially adopts the idea that the “mismatches” are not mismatches at all, but in fact directly reflect exceptional syntactic structure: deponents surface with non-active morphology because the structure is not that of a transitive verb.

In this paper, we offer an argument from Hittite (Anatolian, Indo-European) in support of the view that apparent mismatches between morphology and syntax are purely morphological in nature. Some patterns of voice morphology cannot be explained by appealing to an exceptional syntactic configuration; rather, they must be encoded as properties of the (post-syntactic) morphological component. Our argument comes from cases of *voice reversal* in Hittite. As we illustrate below, there are instances in Hittite where the voice morphology expressed on the verb “flips” from mismatch to match. We show that this flip is sensitive to morphological rather than to syntactic properties. That is, the flip cannot be explained by appealing to a hierarchical structure, and can only be explained as a product of how morphology spells-out the (features of the) head that is realized as voice morphology. Our conclusion is specifically an argument in favor of the proposal advanced by Wood (2015) and Wood & Marantz (2018), who argue that the head that introduces an external argument (here called Voice) is always projected, whether it introduces an external argument or not — i.e., so-called “expletive” Voice (Schäfer 2008; Alexiadou et al. 2015). We show below that voice reversal requires the presence of an expletive Voice, even in contexts where it cannot be syntactically or morphologically detected (*contra* Schäfer 2008; Alexiadou et al. 2015; Grestenberger 2018).

Our paper has the following structure. We begin in §2 by providing the reader with some general background on Hittite. In §3, we turn to the morphological expression of voice in verbs of different syntactic types; we also describe the form and function of the aspectual morphology that in certain verbal classes affects the distribution of voice morphology. These interactions between aspect and voice are the subject of §4, where we show that only mismatch verbs undergo voice reversal. The next two sections are concerned with the analysis of this pattern. We discuss previous accounts of the distribution of voice morphology in §5, then in §6 proceed to lay out our own proposal. §7 concludes.

2 Background on Hittite

Hittite is the major representative of the extinct Anatolian branch of the Indo-European (IE) language family. Hittite was the official language of the kingdom of Ḫatti, and as such is attested continuously from the 16th–13th centuries BCE in

multi-genre administrative texts, the majority on clay tablets excavated from the royal archives at Hattuša near modern Boğazkale in central Turkey.

Hittite was written in a cuneiform mixed syllabic-logographic script. All examples below are presented in so-called “broad transcription:” syllabic spellings are rendered in lowercase italics (long vowels marked with a macron); Akkadian logograms in uppercase italics; and Sumerian logograms in uppercase Roman letters (superscripted when functioning as determiners). See Hoffner & Melchert (2008: 9–50) for a more detailed description of the writing system, and Yates (2017: 38–40) for a concise overview of the phonological system that it represents.

The Hittite language is chronologically stratified into three stages, conventionally referred to as Old Hittite (OH), Middle Hittite (MH), and New Hittite (NH). The younger periods are distinguished from the older by linguistic innovations at all levels of the grammar (phonological, morphological, syntactic, lexical, etc.). This paper is concerned primarily with Old Hittite (ca. 1650–1450 BCE), where the voice alternations described and analyzed below are consistently maintained (Melchert 2017: 479–80; see further §4 below). Where these alternations are directly relevant, we therefore focus our study on original compositions produced in the Old Hittite period. However, due to the limited size of the Hittite corpus, our general discussion of voice and aspectual morphology in §3 draws on Hittite texts of all periods.

3 Voice and aspect in Hittite

This section is organized as follows. §3.1 presents an overview of Hittite voice morphology, describing its formal, functional, and general distributional properties. §3.2 then discusses some morphosyntactic diagnostics for unaccusative syntax in Hittite, which are then applied in §3.3 to identify a class of unaccusative verbs that exhibit mismatch voice morphology. In §3.4, we describe a second class of Hittite verbs that exhibit voice mismatch, deponents. Finally, §3.5 describes the aspectual morphology that — as will be shown in §4 — interacts with the realization of Voice exclusively in these two exceptional mismatch verb classes.

3.1 *Active vs. non-active voice*

Hittite has a bivalent voice system with an opposition between active (ACT) and non-active (NACT) voice, the latter traditionally called “middle” or “mediopassive” (cf. Hoffner & Melchert 2008: 180). Voice is encoded on the verbal stem by a set of fusional inflectional suffixes, which also mark person (1ST, 2ND, 3RD), number (SG,

PL), mood (IND, IMP), and — for indicative verb forms — tense (NPST, PST);¹ these suffixes are often referred to as inflectional “endings” because they always attach last to the verb and thus coincide with the right edge of the prosodic word.

The Hittite indicative active endings are given in Table 1 and the non-active endings in Table 2.² Note that while all Hittite verbs select the same set of non-active endings, verbal stems with active voice forms belong to one of two conjugational classes, the *mi*-conjugation (class I) or the *hi*-conjugation (class II), which are characterized by partially distinct inflectional endings. A verb’s class membership is a synchronically arbitrary lexical property. Class-specific endings are indicated as such in Table 1 with superscripts.

		SINGULAR	PLURAL
NON-PAST	1ST	$-mi^I, -\underline{h}hi^{II}$	$-weni$
	2ND	$-\check{s}i^I, -tti^{II}$	$-tteni, -\check{s}teni^{II}$
	3RD	$-zzi^I, -i^{II}$	$-anzi$
PAST	1ST	$-(n)un^I, -\underline{h}hun^{II}$	$-wen$
	2ND	$-\check{s}^I, -t, -tta^{II}$	$-tten, -\check{s}ten^{II}$
	3RD	$-t(ta)^I, -\check{s}^{II}$	$-er$
IMPERATIVE	1ST	$-allu$	$-weni$
	2ND	$-\emptyset, -t^I$	$-tten$
	3RD	$-ttu^I, -u^{II}$	$-antu$

Table 1: Hittite active endings.

It can be observed in Table 2 that non-past tense non-active endings are optionally characterized by a particle $-ri$. Past tense non-active endings are distinguished from non-past by the presence of a final t , to which a particle $-i$ may be optionally added.

The distribution of active and non-active voice morphology in Hittite is broadly similar to its distribution in other ancient IE languages, such as Ancient Greek,

¹We analyze the verbal endings in Tables 1–2 as unitary suffixes (following Hoffner & Melchert 2008: 181–4), although a case could be made for further segmentation — for instance, the non-active past tense endings in Table 2 are plausibly analyzed as containing a [+PST] marker $/-t/$, or the non-past active endings in Table 1 as containing a [–PST] marker $/-i/$. This analytic choice does not materially affect the analysis developed in §6.

²This presentation simplifies the actual situation somewhat; for a detailed description of the verbal inflectional endings and their distribution see Hoffner & Melchert (2008: 180–4).

		SINGULAR	PLURAL
NON-PAST	1ST	<i>-ḫha(ri), -ḫḫaḫa(ri)</i>	<i>-wašta(ri)</i>
	2ND	<i>-tta(ri)</i>	<i>-dduma(ri)</i>
	3RD	<i>-a(ri), -tta(ri)</i>	<i>-anta(ri)</i>
PAST	1ST	<i>-ḫhat(i), -ḫḫaḫat(i)</i>	<i>-waštat(i)</i>
	2ND	<i>-ttat(i)</i>	<i>-ttumat(i)</i>
	3RD	<i>-at(i), -ttat(i)</i>	<i>-antat(i)</i>
IMPERATIVE	1ST	<i>-ḫḫaru, -ḫḫaḫaru</i>	<i>-waštat(i)</i>
	2ND	<i>-ḫḫut(i)</i>	<i>-ttumat(i)</i>
	3RD	<i>-aru, -ttaru</i>	<i>-antaru</i>

Table 2: Hittite non-active endings.

Vedic Sanskrit, Latin, and Tocharian, or in modern IE languages, such as Modern Greek or Albanian (cf. Grestenberger 2014a: 19–62, 102–5, 2018: 489–91).³ Active morphology is found in a wide range of syntactic contexts, whereas the distribution of non-active morphology is considerably more limited. Many verbs with active forms also surface with non-active morphology; for these verbs, the non-active marked forms are typically associated with a set of distinct functions, which include reflexives, reciprocals, anticausatives, and passives. These “oppositional” functions of Hittite non-active morphology vis-à-vis active morphology are illustrated in (1–4) below:^{4, 5}

³ One respect in which some of these other ancient IE languages (e.g., Ancient Greek, Vedic Sanskrit) differ from Hittite is that they also have dedicated passive morphology available in certain tense/aspect combinations (see Grestenberger 2014a; 2018). Hittite has no dedicated passive morphology.

⁴ The examples in (1–3) show that non-active verb inflection is sufficient to mark these oppositional functions in Hittite. However, it should be noted that non-active marking often cooccurs in these functions (other than passive) with the reflexive particle =z(a). See Hoffner & Melchert (2008: 357–66) for a description of this particle, and for more detailed discussion of its relationship with non-active inflection Boley (1993), Garrett (1996), Luraghi (2010; 2012), Cotticelli-Kurras & Rizza (2011; 2013), Inglese (2020: 148–9, 222–8) Melchert (to appear).

⁵ (1–4) and subsequent examples are generally glossed according to Leipzig conventions. One exception is the use of C for “common gender,” which is the standard term in Hittitological scholarship for animate grammatical gender (in contrast to N = neuter). Clause-connecting particles are glossed CONN.

(1) *suppiyahḥ*– ‘purify’

a. Active transitive:

n=an *šuppiyahḥun*
 CONN=3SG.C.ACC purify.1SG.PST.ACT

‘I purified it.’ (KUB 19.37 ii 17)

b. Non-active reflexive:

[*Nar*]am-^dSIN-*naš* *suppiyahḥati*
 Naram.Sin.C.NOM.SG purify.3SG.PST.NACT

‘Naram-Sin purified himself.’ (KBo 3.16 iii 11)

(2) *zah(h)*– ‘strike’

a. Active transitive:

^dU-*aš* KUR-*e* *zāḥi*
 Storm.god.C.NOM.SG land.N.ACC.SG strike.3SG.NPST.ACT

‘The Storm-god shall strike the land’ (KBo 6.25 + KBo 13.35 iii 5–7)

b. Non-active reciprocal:

takku LU.MEŠ *zahḥanda* *ta* 1-*aš*
 if men strike.3PL.NPST.NACT CONN one-C.NOM.SG
aki
 die.3SG.NPST.ACT

‘If men strike each other and one dies. . .’ (KBo 6.26 ii 16)

(3) *duwarne/a*– ‘break’

a. Active transitive:

takku LÚ.U₁₉.LU-*aš* ELLAM-*aš* QAŠŠU *našma* GÌR-ŠU *kuiški*
 if man.GEN.SG free.GEN.SG his.arm or his.leg someone
tuwa[*rnizzi*]
 break.3SG.NPST.ACT

‘If someone breaks the arm or leg of a free man. . .’ (KBo 6.2 i 20–21; Hoffner 1997: 24–5)

b. Non-active anticausative:

našma GIŠ KAK *duwarnattari*
 or peg break.3SG.NPST.NACT

‘or (if) the peg (of the birthing-stool) breaks...’ (KBo 5.1 obv. i 2; Neu 1968b: 182)

(4) *wemiye/a-* ‘find’

a. Active transitive:

nu=za mahhan eni ṬUPPA ŠA KUR URU Mizri peran
 CONN=REFL when that tablet about.the.land of.Egypt in.front
wemiyānun
 find.1SG.PST.ACT

‘When I found in front of me that tablet about Egypt.’ (KUB 14.8 i 31–2)

b. Non-active passive:

n=at wemiyattaru
 CONN=3SG.N.NOM find.3SG.IMP.NACT

‘Let it be discovered!’

(KUB 14.10 iv 19)

In addition, Hittite has a class of verbs that exhibit only non-active voice morphology in their basic stem forms. Members of this class — referred to here as *media tantum* (“middle only”) verbs — largely belong to semantic classes that tend to appear with non-active voice morphology in bivalent voice systems cross-linguistically (Kemmer 1993, Zombolou & Alexiadou 2014, Grestenberger 2018; 2019, *i.a.*). Such canonical *media tantum* include the Hittite verbs in (5); the behavior of this class is illustrated in (6) with the stative verb *ki-* ‘lie’ and the change-of-state verb *kiš-* ‘become’.

- (5) a. Stative verbs — e.g., *ki-* ‘lie’, *ar-* ‘stand’, *tarra-* ‘be able’, *tukk-* ‘be visible’
 b. Change-of-state verbs — e.g., *eš/aš-* ‘sit down’, *ištu-* ‘become visible/apparent’, *kiš-* ‘happen; become’, *ur/war-* ‘burn’, *zeya-* ‘get cooked’.
 c. Experiencer/psych verbs — *irmaliye/a-* ‘be(come) ill’, *kardim(m)iyē/a-* ‘be(come) angry’
 d. Certain motion verbs — e.g., *iye/a-* ‘walk’.

- (6) a. 2 NINDA.KUR₄.RA KU₇.KU₇ GIŠBANŠUR-*i kianta*
 two bread sweet table.LOC.SG lie.3PL.NPST.NACT
 ‘Two sweet breads lie on the table.’ (KBo 20.8 i 15)

- b. *nu=wa kē urkiēš kišandati*
 CONN=QUOT DEM.C.NOM.PL sign.C.NOM.PL happen.3PL.PST.NACT
 ‘These signs occurred.’ (KuT 49: 4–5)

The Hittite *media tantum* in (5) are not just semantically similar; they are also of a uniform syntactic type: all are syntactically unaccusative. This behavior is confirmed by independent diagnostics, which are discussed further in §3.2 below.

3.2 *Unaccusativity in Hittite*

Unaccusative verbs in Hittite show special morphosyntactic behavior by which they can be distinguished from transitive and even unergative verbs in certain syntactic contexts (cf. Hoffner & Melchert 2008: 280–3, 310 n. 7). The availability of such diagnostics of unaccusativity is an important feature that sets Hittite apart from the other ancient IE languages as well as from many non-IE languages, where the distinction among intransitive verbs between unaccusative and unergative is difficult to verify beyond lexical semantic classification. As will become clear in §4 below, this distinction plays a crucial role in the realization of Hittite voice morphology: (a subset of) unaccusative verbs show voice alternations between their basic stem form and their “imperfective” forms, whereas unergative verbs never show such alternations. This pattern can be observed precisely because the uniform syntax of these intransitive verbs can be reliably determined using independent criteria.

One diagnostic of unaccusativity is the distribution of enclitic pronouns. A unique feature of Anatolian languages like Hittite among the ancient IE languages is the existence of a set of 3rd person subject-marking enclitic pronouns (with gender-specific forms), which are given in (7):

(7)	SG	PL
C.NOM	= <i>aš</i>	= <i>e</i> , = <i>at</i>
N.NOM	= <i>at</i>	= <i>at</i>

The distribution of these enclitic subject pronouns serves as the most important diagnostic of unaccusativity in Hittite. Building on Watkins (1968–9: 93), Garrett (1990b; 1996) has demonstrated that only unaccusative verbs co-occur with these pronouns, which are required when a 3rd person subject is not overtly realized by a DP.⁶ In other contexts, subject pro-drop is obligatory; the enclitic subject pronouns in (7) thus never occur with agentive verbs, either transitive or intransitive (i.e., unergative), as illustrated in (8–9), where the subject is null:

(8) Transitive verb/no DP subject \Rightarrow no subject pronoun:

⁶Watkins (1968–9: 93) first observed that subject-marking enclitic pronouns occur only with intransitive verbs (confirmed by Garrett 1990a). The further restriction to unaccusative verbs was added by Garrett (1990b; 1996).

- a. *nu=kan* ^m*Zidantan* *addaš=šan*
 CONN=PTC Zidanta.ACC.SG father.ACC.SG=his.ACC.SG
kuenta
 kill.3SG.PST.ACT
 ‘Then he killed Zidanta, his father.’ (KBo 3.1+ i 68)
- b. *nu=za=kan* ^{HUR.SAG}*Arinnandan ēpper*
 CONN=REFL=PTC Arinnanda.ACC take.3PL.PST.ACT
 ‘They took Mt. Arinnanda for themselves.’ (KBo 3.4 ii 34)

(9) Unergative verb/no DP subject ⇒ no subject pronoun:

- a. *nu* 3-ŠU *palwait*
 CONN thrice make.noise.3SG.PST.ACT
 ‘He shouted out three times.’ (KBo 26.65 iv 15–17)
- b. *nu* *likzi*
 CONN swear.3SG.NPST.ACT
 ‘Then he shall swear an oath (in support of his claim)’ (KBo 6.2 iv 3)

In contrast, unaccusative verbs like the canonical *media tantum* in (5) above require the 3rd person enclitic subject pronouns in (7) when no DP subject is present; their presence is therefore obligatory in examples like (10):⁷

(10) Unaccusative verb/no DP subject ⇒ **subject pronoun**:

- a. *man=war=aš=mu* ^{LÚ}*MUTI=YA*
 IRR=QUOT=3SG.C.NOM=1SG.DAT husband=my
kišari
 become.3SG.NPST.NACT
 ‘(If . . .), **he** would become my husband.’ (KBo 5.6 iii 12–13)
- b. *n=e* *aranda*
 CONN=3PL.C.NOM stand.3PL.NPST.NACT
 ‘Then **they** stand still.’ (StBoT 25.25 obv. i 6; Neu 1980: 63)

Hittite lacks 1st/2nd person enclitic subject pronouns, and so this diagnostic only applies with 3rd person arguments of unaccusatives verbs.

Unaccusative verbs also pattern differently from agentive verbs with respect to auxiliary selection in the formation of the periphrastic (or “analytic”) perfect

⁷The subject pronouns do not occur, however, when an overt DP subject is present, as can be seen in (6) above.

construction.⁸ The periphrastic perfect in Hittite is functionally and formally similar to ‘have’-perfect constructions in Romance, Germanic, and elsewhere. In Hittite, the lexical verb is realized as a participial form and selects an inflected auxiliary verb, either *ḫark-* ‘have’ or *eš/aš-* ‘be’. The choice of auxiliary verb is syntactically determined: as in (e.g.) Italian or Dutch, agentive verbs employ *ḫark-* ‘have’, but unaccusative verbs instead use *eš/aš-* ‘be’.⁹ This morphosyntactic contrast is exemplified in (11) vs. (12–13) below:

- (11) Unaccusative ⇒ **auxiliary ‘be’**:

nu=kan antuḫšātar kuit
 CONN=PTC population.N.NOM.SG because
INA URU.DIDLI.ḪI.A=ŠUNU EGIR-pa pān
 into.cities=their back go.PTCP.N.NOM.SG
ēšta
 be.3SG.PST.ACT

‘Because the population **had** gone back into their cities. . .’ (KBo 5.6 i 19–20)

- (12) Unergative ⇒ **auxiliary ‘have’**:

mān UN-aš U[(N-ši) men]aḫḫan<da>
 if man.C.NOM.SG man.DAT.SG toward
lingan harzi
 swear.PTCP.N.NOM/ACC.SG have.3SG.NPST.ACT

‘If a man **has** sworn (a false oath) to another man’ (KUB 30.51 i 17–18 + KUB 30.34 i 10; Dardano 2006: 128)

- (13) Transitive ⇒ **auxiliary ‘have’**:

KUR^{URU} Kinza=ya=z ABU=YA taruḫḫan
 land of.Kinza=CONJ=REFL father=my conquer.PTCP.N.NOM/ACC.SG
ḫarta
 have.3SG.PST.ACT

‘Because my father **had** also conquered the land of Kinza.’ (KBo 5.6 ii 19)

⁸Hoffner & Melchert (2008: 310–12) provide a concise description of the formal and functional properties of this construction; for more detailed discussion, see Boley (1984; 1992), Cotticelli-Kurras (1991; 1992; 2015), Garrett (1996), Dardano (2005), Frotscher (2013: 292–6), and Inglese & Luraghi (2020).

⁹On the unaccusative status of *pai-* ‘go’ in (11), see the discussion in §3.3 below with diagnostic example (17a).

Due in large part to the relative infrequency of the periphrastic perfect, most unaccusative verbs — including all of the *media tantum* discussed above — are not attested in this construction. However, in all attested cases the two diagnostics for unaccusativity pattern together: verbs that cooccur with subject clitics also select *eš/aš-* in the periphrastic perfect.

A further notable property of unaccusative *media tantum* is that they often have causative counterparts formed by adding the productive causative suffix *-nu-*, which derives a class I verbal stem.¹⁰ Verbs derived with this suffix are always transitive, and as expected receive active voice morphology in syntactically active contexts, e.g. (14):¹¹

- (14) Causatives in *-nu-* derived from unaccusative *media tantum*:
- a. *tarra-* ‘be capable’ ⇒ *tarra-nu-* ‘make capable/powerful’
(e.g., 3PL.NPST.ACT *tarranuanzi*)
 - b. *ur/war-* ‘burn’ ⇒ *war-nu-* ‘cause to burn’
(e.g., 1SG.NPST.ACT *warnumi*)
 - c. *zeya-* ‘get cooked’ ⇒ *za-nu-* ‘cook’
(e.g., 3SG.NPST.ACT *zanuzzi*)

Just like other transitive verbs formed with *-nu-*, causatives derived from *media tantum* are also compatible with non-active morphology, e.g., in passive or reflexive contexts (Luraghi 1992, Shatskov 2018, Inglese 2020: 171–2). For *war-nu-* in (14b) this usage is attested in (15):

- (15) KUR-*iyaš* *kuraš* IZI-*it* *warnutari*
land.GEN.SG field.C.NOM.SG fire.INS burn.3SG.NPST.NACT
‘The field of the land shall be burnt by fire.’ (KUB 8.25 i 8–9)

3.3 *activa tantum* verbs in Hittite

While many unaccusative verbs in Hittite are *media tantum*, it also has a substantial class of diagnostically unaccusative verbs that surface with only active voice morphology in their basic stem forms. We refer to this class as *activa tantum* (cf. Grestenberger 2018: 501 for the term).

¹⁰Causative *-nu-* also attaches productively to other types of verbal stems, including *activa tantum* (discussed in §3.3 below), and to adjectival roots (e.g., *park-* ‘high, tall’ ⇒ *park-nu-* ‘make high’; cf. ADJ *park-(a)w-* ‘high, tall’). See further Luraghi (1992; 2010; 2012), Shatskov (2018).

¹¹Like the other transitive verbs discussed in §4.1 below, causatives like (19) have imperfective forms that show active inflection in active contexts — e.g., IPFV.3SG.NPST.ACT *warnuškezzi* (KBo 8.96 iii 8), IPFV.3PL.NPST.ACT *zanuškezzi* (KUB 7.1 ii 6).

Hittite *activa tantum* belong broadly to the same semantic classes as unaccusative *media tantum*: compare (16) below with (5) above. Note that, in addition to a number of synchronically non-derived verb stems, the *activa tantum* include the productive class of deadjectival inchoative verbs — traditionally referred to as “fientives” — formed with the suffix *-ešš-* (Hoffner & Melchert 2008: 177–8; cf. Watkins 1971, Hoffner 1998).^{12,13}

- (16) a. Stative verbs — e.g., *eš/aš-* ‘be’, *ḫuiš-* ‘live’, *karuššiyē/a-* ‘be silent’, *išṭandai-* ‘linger’.
 b. Change-of-state verbs — e.g., *ak(k)-* ‘die’, *ḫark-* ‘perish’, *m(a)i-* ‘grow’, *nink-* ‘get drunk’, *park-ešš-* ‘become tall’, *šalli-e(šš)-* ‘become large’, *tepaw-ešš-* ‘become small’
 c. Experiencer/psych verbs — *naḫ(h)-* ‘fear’.
 d. (Certain) motion verbs — e.g., *pai-* ‘go’, *uwa-* ‘come’, *ḫuw(a)i-* ‘move’.

Syntactically, Hittite *activa tantum* behave just like canonical *media tantum*: they obligatorily co-occur with enclitic subject pronouns in the absence of an overt DP subject, as in (17). Once again, this behavior contrasts with that of transitive and unergative verbs like (12–13) above.

- (17) Unaccusative *activa tantum* verb/no DP subject ⇒ **subject pronoun**:

- a. *n=aš* *laḫḫa* *paizzi*
 CONN=3SG.C.NOM campaign.ALL.SG go.3SG.NPST.ACT
 ‘Then **he** goes on campaign.’ (KBo 6.3 ii 48)
- b. *takku ŠAH(-aš)* UR.GI7-*aš* *katta kuiški*
 if pig.GEN.SG dog.GEN.SG with someone.C.NOM.SG
waštai *aki=aš*
 sin.3SG.NPST.ACT die.3SG.NPST.ACT=3SG.C.NOM

¹²The basic stem forms of this class show only active inflection with a single New Hittite exception: *nakkeštat* ‘began to weigh upon’ (KUB 14.4 iii 25); see Melchert (2017: 480) for discussion of this form. The suffix attaches to adjectival stems or to adjective-forming roots — e.g., in (16b) *tepaw-ešš-* derives from the adjective *tep-(a)w-* ‘small’ (cf. root-derived causative *tep-nu-* ‘make small’), but *park-ešš-* directly from the root of *park-(a)w-* ‘high, tall’ (see Hoffner & Melchert 2008: 51–2, 177–8).

¹³The informed reader might wonder whether the classes of *media tantum* and *activa tantum* correlate with the noted (perhaps gradable) distinction between spontaneous and non-spontaneous events (Haspelmath 1993; 2016), which has also been characterized as the difference between internally and externally caused events (Levin & Rappaport-Hovav 1995) (see summarized discussion in Schäfer 2008: 160f, 222f). We do not see any evidence for making such a distinction in Hittite. For instance, the motion verbs in (16) do not describe not internally caused or spontaneous events. Still, finding a lexical-semantically defined natural class of *activa tantum* would not undermine the point we make below about when voice morphology is reversed.

‘If someone sins with a pig (or) a dog, **he** shall die.’ (KBo 6.26 iv 16–17)

- c. *šalliešt=aš* *n=aš*
 large.INCH.3SG.PST.ACT=3SG.C.NOM CONN=3SG.C.NOM
mēani *āraš*
 maturity.LOC.SG arrive.3SG.PST.ACT
 ‘**He** grew up and reached maturity.’ (KBo 32.14 iii 3–4)

Similarly, *activa tantum* contrast with transitive and unergative verbs with respect to their choice of auxiliary in the periphrastic perfect, selecting *eš/aš*– ‘be’ rather than *ḥar(k)*– ‘have’, as in (18) below:

(18) Unaccusative ⇒ **auxiliary ‘be’**:

- a. *man INA* ^{URU}*Ḥayaša pāun=pat* *nu=za*
 IRR to.Hayasa go.1SG.PST.ACT=FOC CONN=REFL
MU.KAM-za *šer tepaweššanza* *ēšta*
 year.C.NOM.SG for small.INCH.PTCP.C.NOM.SG be.3SG.PST.ACT
 ‘I wanted to go also to Hayasa, but the year **had** become too short for me.’ (KBo 4.4 iii 22–3; cf. Goetze 1933: 139)
- b. *KUR* ^{URU}*Nerik ḥūdak=pat* *karūliyaš* *ANA LUGAL* ^{MEŠ}
 land of.Nerik suddenly=FOC former.LOC.PL in.the.kings
karū *ḥarkanza* *ēšta*
 already perish.PTCP.C.NOM.SG be.3SG.PST.ACT
 ‘Already in the time of the earlier kings the land of Nerik **had** suddenly perished.’ (KUB 21.19+ iii 11)

A third way in which unaccusative *activa tantum* behave like *media tantum* is that many of them also form causatives with the suffix *-nu-*. Such causatives are attested for numerous *activa tantum*, e.g., (19); these include non-derived verbal stems like (19a–d), as well deadjectival verbs derived with the suffix *-ešš-* like (19e).¹⁴

(19) Causatives in *-nu-* derived from unaccusative *activa tantum*:

- a. *eš/aš*– ‘be’ ⇒ *aš-nu-* ‘take care of’
 (e.g., 3SG.PST.ACT *aššanut*)

¹⁴Like the other transitive verbs discussed in §4.1 below, causatives like (19) have imperfective forms that show active inflection in active contexts — e.g., IPFV.3PL.NPST.ACT *aššanuškanzi* (HT 1 iv 5), IPFV.1SG.NPST.ACT *ḥuišnuškemi* (KBo 16.24 i 58 + KBo 16.25 i 47), IPFV.3SG.NPST.ACT *ḥuinuškizzi* (KUB 33.115 ii 7), IPFV.3PL.PST.ACT *ḥatkiššanušker* (KUB 15.1 ii 8, 40). For *aš-nu-* ‘take care of’ as the causative of *eš/aš*– ‘be’ see Luraghi (1992), Inglese (2020: 172), and with detailed argumentation Kloekhorst (2008: 216–8).

- b. *huiš-* ‘live’ ⇒ *huiš-nu-* ‘make live, rescue’
(e.g., 1SG.NPST.ACT *huišnumi*)
- c. *huw(a)i-* ‘move’ ⇒ *hui-nu-* ‘make move’
(e.g., 3SG.NPST.ACT *huinuzi*)
- d. *nink-* ‘get drunk’ ⇒ *nink-nu-* ‘make drunk’
(e.g., 3PL.NPST.ACT *ninganuwanzi*)
- e. *hatk-ešš-* ‘become narrow’ ⇒ *hatk-ešš-nu-* ‘cause to become narrow’
(e.g., 2SG.NPST.ACT *hatkišnuši*)

As evident in (19), causatives derived from *activa tantum* take active morphology in syntactically active contexts. However, they can also be passivized with non-active morphology; this pattern is attested for *ašnu-* ‘take care of’ in (19a), e.g., in (20):

- (20) *mahha]n=ma=at=kan ašnuwantari*
 when=TOP=3PL.NOM=PTC take.care.of.3PL.NPST.NACT
n=uš IŠTU Ì.UDU iškanzi
 CONN=3PL.C.ACC with sheep.fat
 ‘When they get taken care of and they smear them with sheep fat, (then...)’
 (KUB 29.40 ii 7; cf. Kammenhuber 1961: 178)

Thus insofar as Hittite *activa tantum* pattern with unaccusative *media tantum* like (5) with respect to the morphosyntactic diagnostics discussed above, they appear to be prototypical unaccusative verbs not just semantically but also syntactically. That is, there is no reason to believe that *activa tantum* and *media tantum* differ syntactically. (We will postpone until §5 explicit discussion of what that structure might be.) Morphologically, however, the *activa tantum* contrast with unaccusative *media tantum*, the former surfacing only with active morphology in their basic stems forms and the latter only with non-active morphology. As pointed out by Grestenberger (2018: 501), “[f]ormally active unaccusative verbs” of this kind are “a major problem for understanding the canonical distribution of voice morphology” in languages with bivalent voice systems: if it is the case that the class of unaccusative verbs which have identical syntactic characteristics and thus presumably have an identical structural representation are realized with non-active morphology (a widely adopted idea since Embick 1998), then the active morphology seen in Hittite *activa tantum* would, descriptively, “mismatch” its syntactic context (cf. Weisser 2014).

One solution to this problem, proposed by Alexiadou & Anagnostopoulou (2004), Schäfer (2008), and Alexiadou et al. (2006; 2015) and adopted by Grestenberger (2018), is that the *activa tantum* differ syntactically from unaccusative *media tantum* in a way that is not reflected in the unaccusativity diagnostics discussed previously — specifically, that the former lack the Voice layer present in the latter,

which is responsible for the realization of non-active morphology. For these authors, the term “mismatch” applied to *activa tantum* is a misnomer, because in fact the morphology *does* reflect the syntax. The details of this proposal are discussed further in §6, where we argue explicitly against this kind of analysis; instead, we contend that Hittite supports the view that unaccusative *activa tantum* are “mismatch” verbs in much the same way as Hittite deponents, which we discuss now in §3.4.¹⁵

3.4 Deponent verbs in Hittite

Although most *media tantum* in Hittite are syntactically unaccusative (like (5) above), Hittite also has a small class of transitive verbs that surface with only non-active morphology in their basic stem forms. Following Grestenberger (2014a; b; 2018; 2019), we refer to verbs with these properties as DEPONENT verbs. Deponents constitute a closed morphological class in Hittite; a complete list of securely attested deponent verbs is provided in (21):¹⁶

(21) Hittite deponent verbs:

<i>ark-</i>	‘climb; mount’	<i>parš(i)-</i>	‘break’
<i>hatta-</i>	‘slit; pierce’	<i>šarra-</i>	‘cross; transgress’
<i>huett(i)-</i>	‘pull; draw’	<i>tuhš-</i>	‘separate; cut off’
<i>iškalla-</i>	‘tear; slit’	<i>wešš-</i>	‘wear (clothes)’
<i>pahš-</i>	‘protect’	<i>wešiyē/a-</i>	‘graze’

¹⁵A reviewer objects to our characterization of *activa tantum* as a mismatch based on typological patterns, since it is fairly common for languages with bivalent voice systems to have a robust class of active-marked unaccusative verbs, in addition to non-active marked ones. Hittite fits this description: unaccusative *activa tantum* are approximately as numerous as unaccusative *media tantum* by type. Whatever its ultimate explanation, this distribution is clearly inherited from Proto-Indo-European (PIE): nearly all cognates of Hittite unaccusative *activa tantum* in the other IE languages also show active inflection (e.g., 3SG.NPST.ACT PIE **h₁és-ti* ‘is’ > Hitt. *ēšzi*, AGk. *estí*, Ved. *ásti*), and similarly, cognates of *media tantum* show non-active inflection (e.g., 3SG.NPST.NACT PIE **k_éy-(t)or* ‘lies’ > Hitt. *kitta*, AGk. *keítai*, Ved. *sáye*) (see Rix & Kümmel 2001, s.vv). Fundamentally, our point is one of class membership: among the unaccusatives, some are marked with non-active, some are marked with active. We further believe that characterizing the active morphology as “mismatched” in this context offers an explanation for why this class — and only this class — of unaccusatives exhibits voice reversal.

¹⁶See Grestenberger (2014a: 265–76) for an assessment of the evidence. From her list we exclude only *hanna-*, in this respect following Puhvel (1991a: 77–84), who argues that the verb is fundamentally intransitive with the meaning ‘litigate; pass judgement’ and that its marginal transitive usage (only with internal cognate object *haneššar/n-* ‘judgement’) is a calque on an Akkadian legal formula (cf. Inglese 2020: 371–4).

While deponent verbs differ morphologically from active-marked transitive verbs, syntactically they behave in the same way: deponents take direct objects marked with ACC case and never co-occur with enclitic subject pronouns. The examples in (22a–b) illustrate accusative object marking, while (22c) with null subject further demonstrates that deponents do not occur with subject pronouns.

- (22) a. ^dIM-*aš*=*wa* LUGAL-*un* SAL.LUGAL-*ann*=*a*
 storm-god.C.NOM.SG=QUOT king.C.ACC.SG queen.C.ACC.SG=CONJ
aššuli *paḥšaru*
 goodness.LOC.SG protect.3SG.IMP.NACT
 ‘May the Storm-god protect the king and the queen in goodness.’ (KUB 30.40 iii 4–6)
- b. *n*=*ašta* EN.SISKUR ANA NINDA.GUR₄.RA *awan arḥa*
 CONN=PTC ritual.client from thick.loaf INT.away
tepu *paršiya*
 small.N.ACC.SG break.3SG.NPST.NACT
 ‘The ritual client breaks off a little (piece) from the thick loaf.’ (KBo 13.164 iv 6)
- c. *kinun*=*a* 1 UDU LU-*naš* *kāššaš*=(*š*)*aš*
 now=TOP 1 sheep man.C.GEN.SG in.place.of=his
ḥuittiyanta
 draw.3PL.NPST.NACT
 ‘But now in place of the man they shall drag in one sheep.’ (KBo 6.26 i 41)

In addition, there is some evidence (albeit limited) to suggest that deponents select ‘have’ in the periphrastic perfect construction just like active-marked transitive verbs; this pattern can be observed in (23):¹⁷

- (23) Deponent ⇒ auxiliary ‘have’:

parkuwa=*ya* TÚG.HI.A *waššan*
 clean.N.ACC.PL=CONJ clothes wear.PTCP.N.NOM/ACC.SG
ḥarkandu
 have.3PL.IMP.ACT

‘And let them have worn clean clothes.’ (KUB 13.4 i 16)

¹⁷The interpretation of (23) is disputed. For discussion see Inglese & Luraghi (2020), who argue that (23) is instead an example of the “stative construction” (Hoffner & Melchert 2008: 311–2), which is formally similar to but grammatically distinct from the periphrastic perfect.

However, one respect in which deponent verbs differ from active-marked transitive verbs is that they appear to lack corresponding finite passive forms.¹⁸ Grestenberger (2018: 496–7) suggests that this fact should be understood as a morphological blocking effect: passivization is unavailable for deponents because the non-active morphology regularly used to form passives of transitive verbs (see §3.1 above) is already employed in their syntactically active forms.¹⁹

Thus, the only clear difference between deponents and active-marked transitive verbs is in their morphology: deponents exhibit non-active inflection, which in this syntactic context is anomalous within Hittite and cross-linguistically.

3.5 “Aspect” in Hittite

The preceding sections identified two classes of Hittite verbs which exhibit a mismatch between syntax and morphology: *activa tantum*, which are syntactically unaccusative but take active inflectional endings (3.3); and deponents, which are syntactically transitive but take non-active inflectional endings (3.4). These two mismatch classes are emboldened in Table 3, which summarizes the relationship between syntax and voice morphology in the Hittite verbal classes discussed above.

In §4 below, we will show that the two mismatch verbal classes in Table 3 also interact in an idiosyncratic way with what are traditionally referred to as “imperfective” suffixes (Hoffner & Melchert 2008: 318). This section provides a concise description of the formal and functional properties of these suffixes. The labels “imperfective” and “imperfective stem” are used descriptively to refer to these suffixes and verbal stems containing them; we return to the issue of their exact grammatical function at the conclusion of the section.

¹⁸Note, however, that after historical deponents switch to active inflection in the post-Old Hittite period (see §4.3 below), they can be passivized with non-active morphology (cf. Grestenberger 2014a: 268–76, Inglese 2020: 218–21, Melchert to appear).

¹⁹While the Old Hittite data is consistent with a blocking analysis of deponents, it should be noted that the facts surrounding the Latin deponents discussed by Grestenberger (2018: 498, 517–20) are disputed. Specifically, her claim that deponents lack finite or infinitival passive forms is at odds with what is reported in most grammatical descriptions of Latin (e.g., Hofmann 1910: 31–5, Flobert 1975: 343–80, Pinkster 2015: 283–4; cf. Embick 2000: 194). She proposes that apparent finite and infinitival passives to deponents discussed in this literature are actually formed from historically deponent verbal stems that have been synchronically reanalyzed as regular alternating transitive verbs. However, a “neo-active” stem of this kind is not attested for all such passivized deponents. For instance, well-attested deponents like *sequor* ‘follow’ and *mētior* ‘measure’ (and compound forms thereof, *adsequor*, *dīmētior*, etc.) have passive forms — e.g., INF.PASS *sequī* (*Rhet. Her.* 3.5.2), *adsequī* (*Cic. Verr.* 2.2.181), *mētīrī*, (*Caes. BGall.* 1.16.5); IPFV.3SG.PASS *dīmētīātur* (*Vitr. De arch.* 3.5.8, 12) (cf. Flobert 1975: 349–60) — but no active inflected forms ever occur. If it is the case, then, that Latin deponents could be passivized, the apparent impossibility of passivizing Hittite deponents may require an alternative explanation.

	ACTIVE MORPHOLOGY	NON-ACTIVE MORPHOLOGY
ACTIVE SYNTAX	Transitive/Ergative	Deponents
NON-ACTIVE SYNTAX	<i>activa tantum</i>	<i>media tantum</i>

Table 3: Syntax and voice morphology of Hittite verb classes.

Hittite has four verb-forming suffixes that attach to a root or verbal stem and determine its conjugational class (I or II).²⁰ One is the productive causative suffix *-nu-* (class I), which was discussed already in §3.2 and §3.3 above. The other three are the imperfective suffixes *-ške-* (class I), *-anna/i-* (II), and *-šša-* (II) (Hoffner & Melchert 2008: 322–3). The latter two suffixes have a restricted distribution: just a few verbs use *-šša-* to form their imperfective stems, while *-anna/i-* is associated especially (although not exclusively) with the deponent verbs listed in (21) above.²¹ The suffix *-ške-*, in contrast, is highly productive: it is regularly employed by the vast majority of Hittite verbs to form their imperfective stems and in this function spreads diachronically at the expense of the other two suffixes.²² The usage of these deverbal suffixes is illustrated in (24–26):

(24) Imperfective *-ške-*:

- a. *da-* ‘take’ : *da-ške-* ‘take.IPFV’
- b. *mem(a)i-* ‘speak’ ⇒ *memi-ške-* ‘speak.IPFV’
- c. *eku/aku-* ‘drink’ ⇒ *akku-ške-* ‘drink.IPFV’

(25) Imperfective *-anna/i-*:

- a. *ḫatta-* ‘pierce’ ⇒ *ḫatt-anna/i-* ‘pierce.IPFV’

²⁰Hittite also has a single deverbal infix *-ni(n)-* (class I) which — like the suffix *-nu-* — forms causatives from stative verbs, e.g., *ḫark-* ‘perish’ ⇒ *ḫar-ni(n)-k-* ‘cause to perish; destroy’, *ištark-* ‘be sick’ ⇒ *ištark-ni(n)-k-* ‘make sick’ (cf. Hoffner & Melchert 2008: 179). This infix is not productive in Hittite, as evidenced (among other things) by the tendency for infixed causative verb stems to be replaced over time by *-nu-*-suffixed causative stems, e.g., *ḫarg-nu-* ‘destroy’. For detailed discussion of this tendency and of the prehistory of the infix, see Yates (2015: 169–74) (cf. Shatskov 2018).

²¹The distribution of the imperfective markers appears to just be lexically determined. There is some correlation between *-anna/i-* and deponents, but there are exceptions in both directions, and there is no widely accepted explanation of the correlation among specialists. The suffix *-šša-* is likewise hard to explain: it occurs on just four verbs which have nothing obvious in common, semantically (‘call’, ‘make, do’, ‘get angry’, ‘help’) or grammatically (different conjugational classes, inflectional patterns, etc.).

²²Thus in New Hittite, e.g., *walḫ-anna/i-* in (25c) is replaced by *walḫi-ške-* ‘id.’, and beside older *ḫalzi-šša-* is also attested *ḫalzi-ške-* ‘id.’ (cf. Hoffner & Melchert 2008: 323).

b. *tuhš-* ‘separate’ ⇒ *tuhš-anna/i-* ‘separate.IPFV’

c. *walh-* ‘strike’ ⇒ *walh-anna/i-* ‘strike.IPFV’

(26) Imperfective *-šša-*:

a. *halz(a)i-* ‘call’ ⇒ *halzi-šša-* ‘call.IPFV’

b. *š(a)i-* ‘press’ ⇒ *ši-šša-* ‘press.IPFV’

Imperfective verbal stems of the type in (24–26) are associated with a range of aspectual meanings, including continuative, habitual, distributive, frequentative, and iterative.²³ These readings are exemplified in (27–31):²⁴

(27) Continuative:

kuitman=ma=z=(š)an BEL SÍSKUR IŠTU SAG.DU=ŠU tētan
 while=TOP=REFL=PTC ritual.client from head=his hair.C.ACC.SG
laplē[pan] enērann=a hūittiyannai
 eyelash.C.ACC.SG eyebrow.C.ACC.SG=CONJ pull.IPFV.3SG.NPST.ACT
 MUNUS ŠU.GI=*ma luwili kiššan hūkkiškezzi*
 woman=TOP in.Luwian as.follows recite.IPFV.3SG.NPST.ACT

‘While the ritual client is pulling the hair, lashes, and brows from his own head, the Old Woman is reciting in Luwian as follows.’ (KUB 32.8 iii 6–10)

(28) Habitual:

ANA DUMU.NAM.LÚ.U₁₉.LU=pat=kan anda memian.C.ACC.SG
 in mortal.LOC=FOC=PTC among word
kišan mem[i]škanzi
 as.follows speak.IPFV.3PL.NPST.ACT

‘Among mortals they have a saying: “. . .”’ (KUB 21. 27 ii 15–16)

²³There is a large body of literature on the distribution and semantics of Hittite imperfective verbal stems, especially those formed with the suffix *-ške-*; see Bechtel (1936), Dressler (1968), Puhvel (1991b), Melchert (1998), Hoffner & Melchert (2002, 2008: 317–29), Cambi & Bertinetto (2006), Cambi (2007), Daves (2009; 2010; 2012), and Inglese & Mattioli (to appear).

²⁴We use the term “frequentative” in (30) to refer to cases in which the event named by the verb is repeated on multiple distinct occasions, and contrast this with “iterative” in (31), which we use to refer to cases in which the event consists of multiple subevents repeated on the same occasion (cf. Mattioli 2019: 23–4). This usage corresponds approximately to Schultze-Berndt’s (2012) distinction between “event-external” and “event-internal iterativity,” or to Cusic’s (1981) “occasion-external” vs. “occasion-internal pluractionality.” Inglese & Mattioli (to appear) also make a distinction between “habitual” and “generic imperfective;” under their definitions, (28) would be classified as the latter (the former would include, e.g., *pišker* in (33) below).

(29) Distributive:

n=ašta EN ÉRIN.MEŠ *šarikuwan* 1-*an* 1-*an*
 CONN=PTC army.commander š-troop.C.ACC.SG 1.C.ACC.SG 1.C.ACC.SG
anda tarniškezzi
 in let.IPFV.3SG.NPST.ACT

‘And the army commander admits one š-troop after another.’ (VS 28.30 iii 16–7)

(30) Frequentative:

tūriyanzi=ma=aš *mašiyanki* *nu*
 hitch.up.3PL.NPST.ACT=TOP=3PL.C.ACC how.many.times CONN
 KASKAL-*ši* KASKAL-*ši=pat* INA 7.IKU.^{H1.A} *anda*
 occasion.LOC.SG occasion.LOC.SG=FOC for.7.IKUs in
penneškanzi
 drive.IPFV.3PL.NPST.ACT

‘But as many times as they hitch them up, each time they drive them 7 IKU-measures.’ (KBo 3.5 ii 13–5)

(31) Iterative:

- a. ^{LU}SANGA=*ma=kan* *IŠTU GÌR.GÁN KÙ.BABBAR GEŠTIN*
 priest=TOP=PTC from.a.bowl silver wine
haniškizzi=pat
 draw.liquid.IPFV.3SG.NPST.ACT
 ‘The priest keeps dipping up wine from a silver bowl (and pouring it out into other cups).’ (KBo 15.37 v 8–11 +)
- b. *kētt=a* *kētt=a* GI-*an*
 on.this.side=CONJ on.this.side=CONJ arrow.C.ACC.SG
huiittiannāi *tarnāi=ma=an*
 draw.IPFV.3SG.NPST.ACT release.3SG.NPST.ACT=TOP=3SG.C.ACC
natta ū *halziššai*
 NEG ee.ee cry.aloud.IPFV.3SG.NPST.ACT
 ‘He keeps drawing his arrow toward this side and that, but he does not let it go, and he keeps shouting “ee ee!”.’ (KBo 17.43 i 10–11)

Two additional facts about Hittite imperfectives can be observed in these examples. The first is that any of the meanings in (27–31) can also be expressed by a verb’s basic stem (i.e., without an imperfective suffix).²⁵ Thus, for instance, in (30)

²⁵cf. Hoffner & Melchert (2008: 317–8): “Any basic verbal stem in Hittite may be read as perfective or imperfective, provided that its inherent meaning and the context are appropriate. . . verbs may

both *penneškanzi* ('they drive') in the main clause and *turiyanzi* ('they hitch up') in the preceding adjoined relative clause function as frequentatives, but only the former contains an imperfective suffix.²⁶ Further support for this view comes from cases in which a verb's imperfective stem stands in correspondence with its basic stem in different copies of the same Hittite text, e.g., *tūriezzi* ('he harnesses'; KBo 6.2 iii 60) : *tūriškizzi* ('id. '; KBo 6.3 iii 65) (cf. [Inglese & Mattiola to appear](#)); this apparent interchangeability suggests that these forms could be perceived by Hittite scribes as functionally equivalent.

The second is that all three Hittite imperfective suffixes are grammatically equivalent ("suppletive allomorphs of a single morpheme" per [Melchert 1998](#): 414). Their functional identity is supported, in particular, by examples like those in (31), where iterativity is expressed by a *-ške-* marked verbal stem in (31a) and by *-šša-* and *-anna/i-* marked stems in (31b). Their equivalence is confirmed, moreover, by the "supine construction" ([Hoffner & Melchert 2008](#): 322, 338), a type of periphrastic ingressive/inchoative construction meaning roughly 'begin to *X*' in which a finite form of the verb *d(a)i-* 'place' or *tiye/a-* 'step; take one's place' combines with a verbal noun in its lexical value (i.e., *X* is the lexical meaning of the verbal noun). This construction requires that the verbal noun be formed from a marked imperfective stem (by adding a nominalizer suffix *-wan*); as evident in (32), any one of the three imperfective suffixes satisfies this requirement:

- (32) a. *nu=mu* *ÉRIN.MEŠ peškewan* *dāir*
 CONN=1 SG.DAT troops give.IPFV.SUP place.3PL.PST.ACT
 'They began giving me troops.' (KBo 3.4 iii 24)
- b. *LU.MEŠ MUḪALDIM ḫuganniwan* *[t]ianzi*
 cooks slaughter.IPFV.SUP place.3PL.NPST.ACT
 'The cooks began slaughtering.' (KBo 17.74 + KBo 21.25+ i 44)
- c. *nu* *ēšhar=šummit* *eššuwān* *tiyēr*
 CONN blood.ACC=3PL.ACC.SG do.IPFV.SUP step.3PL.PST.ACT
 'They began killing them (lit. 'making their blood').' (KBo 3.1 i 21-3)

The range of meanings available to verbal stems marked with these suffixes have led some scholars to analyze them as markers of imperfective aspect ([Cambi & Bertinetto 2006](#), [Cambi 2007](#)). Alternatively, [Inglese & Mattiola \(to appear\)](#) argue (building on [Dressler 1968](#)) that the suffix *-ške-* in particular is a pluractional

also optionally mark imperfective aspect explicitly by the addition of *-ške-*, *-šša(a)-*, and *-anna/i-*.²⁶ For further discussion see [Dressler \(1968\)](#), [Daues \(2009\)](#), and [Inglese & Mattiola \(to appear\)](#).

²⁶But compare (27), where both *ḫūkkiškezzi* ('is reciting') in the main clause and *ḫūtiyannai* ('is pulling') in the subordinate clause (introduced by *kuitman* 'while') are marked by an imperfective suffix.

marker, which could naturally extend to the other imperfective suffixes. Which of these analyses is correct will have implications for the morphosyntax of Hittite imperfectives. Whereas an imperfective marker would be expected to head the functional projection associated with grammatical aspect (“viewpoint aspect” in the sense of Tenny 1987, Smith 1991), van Geenhoven (2004; 2005) analyzes pluractional markers as modifiers of lexical (or “situation”) aspect, which occupy a lower structural position (cf. Laca 2002; 2004a; b; 2006, MacDonald 2008, Travis 2010).

We take no strong stance on this issue here. Under the proposal that we develop in section §6 below, the crucial fact about these suffixes is not their hierarchical structure but their morphological linear position, intervening between the verbal root and voice morphology. For the present, then, we retain the labels “imperfective” for these suffixes and “Aspect” for their functional projection, and leave it to future research to determine the precise syntactic status of these suffixes and, in turn, how they come to stand in this position.

Finally, a reviewer asks whether the aspectual suffixes could not be realizations of the verbalizing head *v*. This is unlikely. The verbalizer *v* has distinct morphological realizations (the causative *-nu-* and the inchoative *-ešš-*, discussed in §3.3). As these are not in complementary distribution with any of the aspectual suffixes, we conclude that they are not in competition to realize the same head.

4 Interactions between aspect and voice

Having established the formal and functional properties of Hittite voice and aspectual morphology in the preceding section, we now turn to the issue of how aspect affects the realization of voice morphology. As we will show in §4.1, the selection of active or non-active inflectional endings for imperfective stems is in general governed by the same syntactic factors as their corresponding basic stem forms. Yet there are two verbal classes in Hittite that flout this generalization: deponents and *activa tantum*. In §4.2 and §4.3, we will demonstrate that these two classes, which were shown in §3.3 and §3.4 respectively to show “mismatch” voice morphology in their basic stem forms, exceptionally exhibit an apparent interaction between aspect and voice. Specifically, imperfective forms of these verbs instantiate a pattern that we refer to as *voice reversal*: the imperfective stem shows the opposite voice morphology as the basic stem in syntactically equivalent contexts.²⁷ Having presented the data, we then

²⁷Hittite *activa tantum* and deponents could be classified as “semi-deponents” in the sense of Grestenberger (2019), since they exhibit a “mismatch” between morphology in syntax only in a particular environment (viz., their basic stem form). Grestenberger discusses a case of semi-deponency in Ancient Greek that is somewhat similar to the pattern seen in Hittite *activa tantum*:

summarize the distribution of voice morphology in Hittite and offer a preliminary interpretation of this distribution in §4.4.

4.1 *Non-interactions between aspect and voice*

We begin with the general case. Transitive verbs whose basic stem forms show active morphology in syntactically active contexts have imperfective stems that also show active marking in these contexts. This generalization is exemplified with the verb *p(a)i-* ‘give’ in (33), where the basic stem and imperfective stem occur in effectively identical contexts and both receive active endings:

- (33) *kāru* 1 MA.NA KÙ.BABBAR *pišker* *kinun=a*
 formerly one mina silver give.IPFV.3PL.PST.ACT now=TOP
 20 GÍN KÙ.BABBAR *pāi*
 twenty shekel silver give.3SG.NPST.ACT
 ‘In the past they would give one mina of silver, but now one gives twenty shekels of silver.’ (KUB 6.2 i 9–10)

Similarly, the imperfective stems of the transitive verbs in (34–36b) show the same active marking as their corresponding basic stems in (34–36a). Note, too, that these imperfective stems are also compatible with non-active marking, in which case they exhibit the same set of functions as their basic stems do in non-active contexts — e.g., passive in (34c) and (35c), reflexive in (36c):²⁸

- (34) *ariye/a-* ‘determine by oracle’:
 a. *zankilatar=ma ariyanzi*
 penalty.N.ACC.SG=TOP determine.by.oracle.3PL.NPST.ACT
 ‘They determine the penalty by oracle.’ (KUB 22.40 ii 23)
 b. *nu ABU=YA ariškit*
 CONN father=my determine.by.oracle.IPFV.3SG.PST.ACT
 ‘And my father kept inquiring by oracle.’ KUB 14.13 obv. 50)

some formally active (or alternating) verbs switch to non-active inflection without any apparent change in function (modulo tense) when the future suffix *-se/o-* is added to the stem. However, one important respect in which these Greek semi-deponents differ is that the set of verbs that undergo the voice alternation is not synchronically predictable, whereas in Hittite it systematically affects only *activa tantum* and deponents.

²⁸Examples (34–36c) come from New Hittite manuscripts, but a likely Old Hittite example of a non-active marked imperfective with reflexive function is *n=e...zahhiškanta* ‘And they... strike each other’ (KBo 17.36 ii 15–16), where IPFV.3PL.NPST.NACT *zahhiškanta* corresponds to active *zah(h)-* ‘strike’ in (2) above (cf. Melchert to appear : n. 2).

- c. *apāšš=a* *apiya*
 DEM.C.NOM.SG=CONJ then
arieškattari
 determine.by.oracle.IPFV.3SG.NPST.NACT
 ‘That one too shall then be investigated by oracle.’ (KUB 5.6 ii 37)

(35) *hulle/a-* ‘fight, defeat’:

- a. *n=an* *hullaši*
 CONN=3SG.C.ACC defeat.2SG.NPST.ACT
 ‘And then you shall defeat him.’ (KUB 37.223 rev. 7)
- b. LÚ.MEŠ^{URU} *Azzi=ma* ^dUTU=*ŠI* *kuit karū*
 men of.Azzi=TOP majesty=his because formerly
hulliškenun
 defeat.IPFV.1SG.PST.ACT
 ‘Because I had already defeated the men of Azzi. . .’ (KBo 4.4 iii 60)
- c. *kūš* LUGAL ÉRIN^{ME[Š]} *ŠU-TUM kuezza*
 DEM.NOM.PL of.king troops š-. what.INS
hulliškattari
 defeat.IPFV.3SG.NPST.NACT
 ‘By what were these š-troops of the king defeated?’ KUB 16.18 + KUB 50.30
 obv. 1–2)

(36) *mugai-* ‘incite, rouse’:

- a. *n=an* *INA UD.3.KAM mūgāmi*
 CONN=3SG.C.ACC for.3.days incite.1SG.NPST.ACT
 ‘I incite her for three days.’ (KUB 9.27 + KUB 7.8 i 5)
- b. *nu=tta* *kāša* *mukiškemi* ^{NINDA} *haršit*
 CONN=2SG.ACC right.now incite.IPFV.1SG.NPST.ACT bread.INS
^{DUG} *išpanduzit*
 libation.INS
 ‘I am hereby inciting you with bread (and) libations.’ (KUB 24.2 obv. 12)
- c. *nu=za* ^dUTU ^{URU} *Ari[nna=y]a zikila*
 CONN=REFL Sun-goddess of.Arinna yourself
mukeškeḥhut
 incite.IPFV.2SG.IMP.NACT
 ‘And you yourself, O Sun-goddess of Arinna, bestir yourself!’ (KUB 24.3 iii
 12–13)

Unergative verbs behave similarly when an imperfective suffix is present. Unergative verbs that receive active morphology in their basic stem forms show the same marking in their imperfective stems. This pattern is illustrated in (37–38) with the verbs *palwai-* ‘make noise’ and *link-* ‘swear’. The unergative syntax of these verbs in their basic stem forms was established already in (9a) and (9b) above; the absence of subject clitics with their imperfective stems in (37–38) is likewise indicative of unergativity.

- (37) [HAZ]ZINNA *paltani=šši* *dāi* *peran=a*
 axe shoulder.LOC=his.LOC place.3SG.NPST.ACT before=TOP
palwiškizzi
 shout.IPFV.3SG.NPST.ACT

‘He places the axe on his shoulder and he cries out in front.’ (KBo 25.109 iii 7)

- (38) *nu* ŠA KUR URU *Pītašša ku[...]* *karū* *linkiškkit*
 CONN of.land of.Pitassa already swear.IPFV.3SG.PST.ACT

‘Concerning the land of Pītašša he had already sworn (an oath).’ (KUB 14.1 rev. 50–1)

The situation with imperfective stems of unaccusative *media tantum* verbs is less certain due to the poverty of evidence for this type.²⁹ What little evidence is available, however, suggests that these verbs show the same non-active marking in their imperfective stems as in their basic stem forms, as can be seen in (39) with the *-ške-* suffixed imperfective of the *media tantum* *eš/aš-* ‘sit down’. A second likely example is (40), where the imperfective suffix *-ške-* attaches to a reduplicated form of the *media tantum* verb *ištu-* ‘become evident’; the resulting stem *išdušduške-* exhibits non-active marking just like its base *ištu-*. Dempsey (2015) has shown that verbal reduplication in Hittite is associated with fundamentally the same set of aspectual functions as the imperfective suffixes, and these two marking strategies often co-occur as in (40) (with semantically “reinforcing” effect per Dempsey). We assume that the diagnostic value of this form is not compromised by the presence of reduplication, which on its own does not otherwise appear to have any effect on

²⁹The dearth of evidence for imperfective stems of unaccusative *media tantum* is partially due to the fact that imperfective stems of stative verbs are rare or unattested in Hittite (Bechtel 1936; cf. Hoffner & Melchert 2008: 318, Inglese & Mattiola to appear). This semantic restriction appears to be characteristic of pluractional markers cross-linguistically (Mattiola 2019: 144). Note, also, that we exclude here *iyanna/i-* ‘set out’, which is sometimes analyzed as the *-anna/i-* suffixed imperfective of the *media tantum* *iyela-* ‘walk’ (e.g., Hoffner & Melchert 2008: 318). We follow Puhvel (1984: 328), *HW*² I: 1–4 and Kloekhorst (2008: 375–6) in analyzing this verb instead as the lexicalized, historical imperfective of the PIE root **h₁ei-* ‘go’, whose Hittite reflex survives only marginally as an independent verb (*opp.cit*). For discussion of the possible historical implications of its active inflection, see Yates (2018).

voice morphology: for instance, the transitive verb *par(a)i-* ([pr(a)i-]) ‘blow’ has a reduplicated stem *paripr(a)i-* ([pri-pr(a)i-]), both of which take active endings in syntactically active contexts (e.g., 3PL.NPST.ACT *priyanzi* (KUB 2.3 ii 30) : *parippiyanzi* (KBo 15.49 iv 9)), and similarly — a more direct parallel for *ištu-* — the unaccusative *media tantum* verb *kiš-* ‘happen; become’ has a reduplicated stem *kikkiš-* that likewise shows non-active marking (e.g., 3SG.NPST.NACT *kišari* (KUB 1.13 i 13) : *kikkištāri* (KUB 14.5 rev. 10)).³⁰ In addition, the alternating verb *nai/ne-* ‘turn’, which in the intransitive sense ‘turn oneself’ exhibits only non-active inflection, also shows non-active inflection in imperfective forms with this meaning, as in (41).

- (39) GÚ^{HI.A}-aš=(š)maš ēskidumat
back.LOC.PL=3PL.DAT sit.IPFV.2PL.IMP.NACT
‘Sit down on their backs!’ (KUB 12.63 + 36.70 obv. 5)
- (40) n=ašta IŠTU É^{HI.A} DINGIR^{MES} É.LUGAL=ya p[(rā)]
CONN=PTC from houses of.gods house.of.king=CONJ forth
dušgarannašš=a memiyaš GIŠ^dINANNA-aš
joy.GEN.SG=CONJ word.C.NOM.SG Ishtar-instrument.GEN
g[alg(altūriyaš)] ha[(lugaš)]
tambourine.GEN message.C.NOM.SG
išdušduškettaru
RED.become.evident.IPFV.3SG.IMP.NACT
‘Forth from the temples and the palaces let even the word of joy, the message of the Ishtar-instrument(s) (and) of the tambourine(s) resound!’ (KBo 52.85 + KUB 43.58 ii 53–4; Strauß 2006: 337)
- (41) n=ašta apāš LÚKÚR kuwapi naiškittari
CONN=PTC DEM.C.NOM.SG enemy where turn.IPFV.3SG.NPST.NACT
nu=mu hatreški
CONN=1SG.DAT write.IPFV.2SG.IMP.ACT
‘Keep writing me as to where that enemy is turning.’ (HKM 27: 8–10)

The examples in (34–41) uniformly support the view that imperfective stems exhibit the same voice morphology as do their bases in equivalent syntactic contexts. This distribution suggests that voice is fundamentally independent of aspect in Hittite, the latter having no effect on its realization. To reiterate: aspectual morphology appears consistently with both active and non-active morphology, and the morphological realization of voice is contingent on and predictable from the syntactic context.

³⁰On the reduplicative patterns of *išdušduške-* and *paripr(a)i-* see Yates & Zukoff (2018).

Before proceeding to the two verbal classes that problematize this generalization, however, it is necessary to briefly discuss the chronology of the preceding examples. In §4.2 below, we demonstrate that in Old and Middle Hittite imperfectives of unaccusative *activa tantum* show voice reversal vis-à-vis their basic stem forms. It is therefore crucial that (37–38) and (39–40) are attested in Middle Hittite: these examples provide evidence for a synchronic contrast in the older language (i.e., prior to New Hittite) between unaccusative *activa tantum* and other intransitive verbs — on the one hand, active-inflecting unergative verbs, and on the other, non-active inflecting unaccusative *media tantum* — whereby only the unaccusative *activa tantum* exhibit voice reversal.³¹ Similarly, §4.3 below shows that imperfectives of deponents show voice reversal in Old Hittite; it is important, then, that (33) also occurs in Old Hittite, since it shows that ordinary transitive verbs with active-inflecting basic stems do not show voice reversal in their imperfective stem during this period.

4.2 *Interactions between aspect and voice in activa tantum*

In contrast to the deponents examined in §4.3 below, the distribution of voice morphology in Hittite *activa tantum* has been previously studied. Concerning this class, the first important observation was made by Watkins (1969: 72), who pointed out that the very frequent unaccusative verbs *pai-* ‘go’ and *uwa-* ‘come’ take only active endings in their basic verbal stem, but almost exclusively non-active endings in their *-ške-* suffixed imperfectives. Neu (1968a: 86–9) noted the same behavior in the verb *ak(k)-* ‘die’ and the productive class of deadjectival change-of-state verbs formed with the suffix *-ešš-* (discussed in §3.3 above).

This pattern of voice reversal has now been systematically treated by Melchert (2017), who established two crucial facts. The first is that it is restricted to unaccusative *activa tantum*. Unergative intransitive verbs with active inflection like *palwai-* ‘shout’ and *link-* ‘swear’ thus exhibit the same active inflection in their imperfective forms as in their basic stem forms, as discussed already in §4.1 above.³² The other is that all unaccusative *activa tantum* consistently show voice reversal in

³¹As observed by Melchert (2017: 482), moreover, imperfective forms of the unergative verbs in (37–38) show consistent active inflection even into New Hittite (18x total attestations for *palwai-*, 6x for *link-*). This behavior contrasts with comparably attested unaccusative *activa tantum*, most of which show some evidence for voice reversal even in New Hittite, where this pattern is no longer obligatory (cf. §4.2 below).

³²The fact that unaccusative *media tantum* do not switch to active inflection in their imperfective forms is not discussed by Melchert (2017); for the evidence and discussion see §4.1 above.

their imperfective forms in Old Hittite.³³ Melchert's (2017) survey of the evidence reveals that exceptions to this pattern — i.e., diagnostically unaccusative verbs with active-inflected imperfective forms — are limited to New Hittite texts and copies of older texts produced during the New Hittite period. Table 4 lists imperfective forms of *activa tantum* attested in manuscripts produced during the Old and Middle Hittite periods.^{34,35}

Yet while voice reversal is exceptionless only in the older language, there are also a number of imperfectives of *activa tantum* that are first attested in New Hittite texts or copies of older texts and show the same voice reversal. Examples of this type are provided in Table 5.³⁶ In New Hittite, however, these imperfectives which exhibit voice reversal coexist with imperfectives that show the same active inflection as their base, e.g.: 3PL.NPST.ACT *paiškanzi* 'they go' (VBoT 74:5); 3SG.NPST.ACT *akkiškezzi* 'he dies' (KUB 9.31 iv 45), 3PL.PST.ACT *gallareške[r]* 'they turned out unfavorably' (KUB 5.22:35). Given such variation, it is difficult to determine the grammatical status of voice reversal for *activa tantum* in New Hittite; however, the exceptionlessness of this pattern in the older language argues that voice reversal was obligatory for this type at least in Old Hittite (and probably beyond into Middle Hittite).

³³See Melchert (2017: 482) for arguments that *šeš/šaš-* '(go to) sleep', which shows both unergative and unaccusative behavior in Hittite, does not falsify this generalization.

³⁴For the reading in Table 4 (b) see Hoffner & Melchert (2008: 184 n. 32); the long vowel in the last syllable is likely due to final lengthening in polar questions (Craig Melchert, p.c.), which in Old Hittite can be marked in this way (Hoffner & Melchert 2008: 348).

³⁵A reviewer wonders how we can be sure that such examples are still unaccusative, and not instead passives of transitive verbs. Although the various diagnostics used by (e.g.) Schäfer (2008) or Alexiadou et al. (2006; 2015) to differentiate unaccusatives from passives in languages with bivalent voice are unavailable in Hittite, we can still be confident that the examples in Table 4 are in fact unaccusatives. It was demonstrated already in §3.3 that when *activa tantum* participate in the causative alternation they show additional derivational morphology — namely, the causative suffix *-nu-* — which is present both when the derived verb takes active morphology (in active contexts) and non-active morphology (in non-active contexts). The absence of this morpheme in the forms in Table 4 thus argues against analyzing them as passives of transitive verbs. Moreover, if it were the case that the non-active morphology found in voice reversal on *activa tantum* was actually the expression of the passive, then we would expect to see instances of *activa tantum* with non-active morphology whether an aspectual suffix is present or not, since passives and imperfectives are, in principle, independent. The fact that *activa tantum* are systematically marked with active morphology is the defining characteristic of this class of verbs. More importantly, the non-active morphology with *activa tantum* is *only* found in the presence of imperfective aspect.

³⁶In Table 5 (j) and (k), the basic verbal stem (marked with a right asterisk) is not independently attested.

	IMPERFECTIVE	ATTESTATION	BASE	
a.	<i>paišgaḥat</i> (1SG.PST.NACT)	KBo 17.1 iv 13	<i>pai-</i>	‘go’
b.	<i>paiškattumā[t]</i> (2PL.PST.NACT)	KBo 8.42 obv. 9.10		''
c.	<i>[(paišk)]attaru</i> (3SG.IMP.NACT)	KBo 25.107:3		''
d.	<i>paiškantaru</i> (3PL.IMP.NACT)	KBo 20.31:9		''
e.	<i>paišketta</i> (3SG.NPST.NACT)	IBoT 1.36 i 63		''
f.	<i>paiškand/ta</i> (3PL.NPST.NACT)	IBoT 1.36 i 60, 61, 63; KUB 13.27 rev. 83		''
g.	<i>[m]arlaiškitta</i> (3SG.NPST.NACT)	KBo 26.136 obv. 10, 11, 14, 15	<i>marl-ešš-</i>	‘become crazed’
h.	<i>[m]arliškitta</i> (3SG.NPST.NACT)	KBo 26.136 obv. 9		''
i.	<i>[u]iškittari</i> (3SG.NPST.NACT)	KUB 14.1 + KBo 19.38 rev. 63	<i>uwa-</i>	‘come’
j.	<i>uiškandari</i> (3PL.NPST.NACT)	IBoT 1.36 i 74		''
k.	<i>uiškantaru</i> (3PL.IMP.NACT)	KUB 31.103 obv. 10		''

Table 4: imperfectives of *activa tantum* in Old and Middle Hittite.

4.3 Interactions between aspect and voice in deponents

Like the *activa tantum* just discussed in §4.2, deponents exceptionally exhibit an interaction between aspect and voice: imperfectives of deponents select active endings in the same syntactic contexts as their base stems select non-active endings. While the evidence for deponents is much less robust (see further discussion below), voice reversal in this class is similarly exceptionless in Old Hittite; imperfectives of deponents attested in original manuscripts of Old Hittite texts are given in Table 6.³⁷

This voice reversal pattern in Hittite deponents has not, to our knowledge, been previously noticed. This is in all likelihood due primarily to the seriously limited nature of the usable evidence, which is restricted by (i) the fact that deponents are rarer by type and token than the unaccusative *activa tantum* and (ii) the well-

³⁷For the restoration in Table 6 (a) see Neu (1980: 120), but because of where the break occurs in the text the active inflection of this form is not assured (e.g., NACT *ḥattan[ianta]* is in principle possible). However, a secure instance of voice reversal for this verb is found in a New Hittite copy of an Old Hittite text (KBo 3.34 i 4): *š=an ḥattanier* ‘And they repeatedly stabbed him’ (CONN.PST 3PL.IPFV.NPST.ACT). This attestation is potentially informative because it occurs in a copy that in other respects appears to be quite faithful to the original (KUB 36.104; cf. Inglese 2020: 284 n. 2), preserving archaic Old Hittite features such as the sentence connective *š(u)* (see Hoffner & Melchert 2008: 390 with references).

	IMPERFECTIVE	ATTESTATION	BASE
a.	<i>akkiškettari</i> (3SG.NPST.NACT)	KUB 14.12 obv. 5, 6; 14.8 obv. 30, 46; rev. 38, 41; KUB 14.11 i 23; KUB 14.10+ i 12, 13; iv 17; KUB 26.86 iii 1; KUB 14.13+ i 50; iv 19, 50	<i>ak(k)–</i> ‘die’
b.	<i>akkiškettat</i> (3SG.PST.NACT)	KBo 16.15 8; KUB 14.12 obv. 3; KUB 14.8 obv. 11–2; KUB 14.14 i 9	”
c.	<i>akki[škantat]</i> (3PL.PST.NACT)	KUB 14.8 obv. 6–7 KUB 14.12 obv. 4	”
d.	<i>ašiwanteškantari</i> (3PL.NPST.NACT)	(KBo 4.14 ii 52)	<i>ašiwant-ešš–</i> ‘become poor’
e.	<i>kallareškattari</i> (3SG.NPST.NACT)	(KUB 5.6 iii 18)	<i>kallar-ešš–</i> ‘turn out unfavorably’
f.	<i>makkiškattaru</i> (3SG.IMP.NACT)	KUB 57.63 ii 41	<i>makk-ešš–</i> ‘become abundant’
g.	<i>nakkieškattari</i> (3SG.NPST.NACT)	KBo 4.14 ii 27	<i>nakki-ešš–</i> ‘become burdensome’
h.	<i>nakkiškantat</i> (3PL.PST.NACT)	KBo 18.15:8	”
i.	<i>palḫiškattaru</i> (3SG.IMP.NACT)	KUB 57.63 ii 15; KUB 57.60 ii 10	<i>palḫ-ešš–*</i> ‘become wide’
j.	<i>pargaweškad[da]ru</i> (3SG.IMP.NACT)	KUB 33.98 iii 15.16 (2x)	<i>pargaw-ešš–*</i> ‘become tall’
k.	<i>parkiškittari</i> (3SG.NPST.NACT)	KUB 33.93 iv 18, 19	<i>park-ešš–</i> ‘become high/tall’
l.	<i>tepaweškeḫhari</i> (1SG.PST.NACT)	KUB 33.105 i 2	<i>tepaw-ešš–</i> ‘become small/less’

Table 5: imperfectives of *activa tantum* in New Hittite.

	IMPERFECTIVE		ATTESTATION		BASE
a.	<i>ḥattan[ianzi]</i>	3PL.NPST.ACT	KBo 25.54+ 20	<i>ḥatta-</i>	‘pierce’
b.	<i>ḥuttiannāi</i>	3SG.NPST.ACT	KBo 17.43 i 3	<i>ḥuett(i)-</i>	‘pull’
c.	<i>ḥuttiannai</i>	3SG.NPST.ACT	KBo 17.18 ii 12	"	"
d.	<i>paršiyannāi</i>	3SG.NPST.ACT	KBo 20.4 iv 6	<i>parš(i)-</i>	‘break’

Table 6: imperfectives of deponents in Old Hittite.

established diachronic tendency for deponents to adopt active inflection in their basic stem forms,³⁸ thus eliminating the mismatch between syntax and voice morphology that is characteristic of this class (cf. §3.4 above).

This tendency can be observed already in Middle Hittite,³⁹ including for all of the deponents that also have imperfective forms attested at this historical stage; thus while these imperfective forms almost consistently show active inflection just like the Old Hittite forms in Table 6, it is not clear that they are examples of voice reversal in the same sense, since they stand beside basic stem forms with active inflection, and are thus consistent with the principle established in §4.1 above that imperfectives in general exhibit the same voice morphology as their basic stem forms in equivalent syntactic contexts. Examples of such contemporaneous attestation in Middle Hittite include: 3PL.IPFV.NPST.ACT *paršiannianzi* (KUB 24.98:11) beside 1SG.PST.ACT *paršīyanun* (KBo 23.27 ii 39) to *parš(i)-* ‘break’; 3SG.IPFV.PST.ACT *šarraškit* (KUB 23.72 obv. 37) beside 3SG.PST.ACT *šarraš* (KUB 23.72 rev. 3) to *šarra-* ‘transgress’; and 3PL.IPFV.IMP.ACT [*t*]*uḥšanniyandu* (KUB 35.146 iii 11 ´) beside *tuhḥuṣzi* (KBo 20.39 l.col. 16 ´) to *tuhš-* ‘cut off’. In the case of *iškalla-* ‘pierce’, the imperfective is attested in Middle Hittite with active inflection (3SG.IPFV.NPST.ACT *iškalliškizzi*; KBo 3.21 i 6), whereas active-inflected forms of the basic stem occur first in New Hittite (e.g., 3SG.NPST.ACT *iškallai*; KBo 6.4 i 39), but their absence during the earlier period may be due simply to accident of attestation.

The imperfectives of deponents that are first attested in New Hittite are for the same reasons non-probative, their active inflection being contemporaneous with

³⁸This tendency was first observed by Neu (1968a: 54–6); see further Houwink ten Cate (1970: 18–20), Hoffner & Melchert (2008: 233–4), Oettinger (2019: 274–5), Inglese (2020: 216–8) (with discussion of parallels elsewhere in the Indo-European family), and Melchert (to appear).

³⁹CHD P: 237 cites an Old Hittite active form *šarret* (KUB 36.106 rev. 5) which, if correct, would be 3SG.PST.ACT and show that *šarra-* ‘transgress’ in particular and perhaps deponents in general had begun to switch to active inflection already in Old Hittite. As argued by Kloekhorst (2008: 728), however, the form is better read as 3SG.NPST.NACT *šarret[ta]* ‘transgresses’ (cf. Melchert to appear : n. 19) with expected non-active inflection and the non-past tense marking demanded by the context (Melchert 1984: 36 n. 18).

or subsequent to the appearance of active inflection in their basic stem forms — e.g., 3PL.IPFV.NPST.ACT *ararkiškanzi* (KUB 11.25 iii 19–24) beside 3SG.NPST.ACT *ārki* (KBo 10.45 iv 32) to *ark-* ‘mount’;⁴⁰ 3SG.IPFV.IMP.ACT *pahḫaškiddu* beside 2PL.IMP.ACT *pahḫašten* (KUB 23.82 rev. 5, 12) to *pahš-* ‘protect’; IPFV.2SG.NPST.ACT *wešieškeši* (KUB 24.7 ii 57) beside 3SG.IMP.ACT *w<e>šeddu* (KUB 30.24 ii 4) to *wešīye/a-* ‘graze’.

In addition, a few apparent counter-examples to voice reversal begin to appear in the post-Old Hittite period. The imperfective of the verb *šarra-* ‘transgress’ shows non-active inflection in its 3SG.NPST form in five independent occurrences (e.g., *šarrašketta*; KUB 36.75+Bo 4696 i 8), as well as once in its 2PL.NPST form (*šarriškettuma*; KUB 34.75:5).⁴¹ There is also a single example of an imperfective to *ark-* ‘mount’ with non-active inflection, 3SG.IPFV.NPST.NACT *arkišketta* (KUB 29.1 i 30). How these non-active forms should be explained is unclear, especially since they occur beside contemporaneous imperfective forms of the same verbs with active inflection, e.g., *šarraš* in Middle Hittite and *ararkiškanzi* in New Hittite (both cited above).

The evidence for voice reversal in deponents is thus somewhat less robust than for the unaccusative *activa tantum* treated in §4.2 above, but the overall picture is broadly similar. The few examples of deponents attested in Old Hittite all show voice reversal.⁴² The later evidence mostly accords with Old Hittite, but its diagnostic

⁴⁰The form *ararkiškanzi* ‘they mount’ is characterized by both reduplication and the imperfective suffix *-ške-* just like *išdušduškettaru* ‘let it become evident’ discussed in §4.1.

⁴¹The other active-inflected attestations of the verb’s 3SG.IPFV form are: [*ša*]rrišketta (KUB 24.3 i 55); 3SG.NPST.NACT *šarriškatta* (KUB 13.4 iii 61; plus duplicate KUB 13.6 iii 12 + KUB 13.19 obv. 3 [*šarre*]škattari); and *šarrašketta* (KUB 13.5 ii 13; KUB 31.134:4 plus duplicate KUB 31.133:11). Note, however, that KUB 31.127+36.79 i 31 has active-inflected *šarreškiši* where KUB 31.134:4 and its duplicate KUB 31.133:11 have non-active *šarrašketta*, and that the same manuscript which has non-active *šarriškatta* (i.e., KUB 13.4 iii 61) elsewhere attests *šarreškezzi* (KUB 13.4 iii 5) with the same meaning. How this variation should be interpreted is at present unclear to us.

⁴²The fact that all imperfectives of Hittite deponents are formed with the suffix *-anna/i-* raises the possibility of an alternative analysis to the one we propose in §6 below — namely, that active inflection is an idiosyncratic property of this suffix (i.e., *-anna/i-* is [+AT]), as is the case for the deadjectival verb-forming suffix *-ešš-*. This analysis, however, would predict that imperfectives in *-anna/i-* are incompatible with non-active morphology. While there are no non-active forms of verbs in *-anna/i-* attested in original Old Hittite manuscripts, there are two forms in later copies of Old Hittite texts which show that transitive verbs in *-anna/i-* can form non-active marked passives: (i) IPFV.3PL.NPST.NACT *nannianta* ‘are driven’ (KBo 21.75:10; cf. *CHD* L–N: 393), the (perhaps lexicalized) imperfective of *nai-* ‘turn’ (Hoffner & Melchert 2008: 323; contra Kloekhorst 2008: 600); and (ii) IPFV.3SG.NPST.NACT *tuhšannatta* (KBo 9.114 lc. 12) ‘is cut off’, the imperfective of deponent *tuhš-* ‘cut off’ (the context is broken, however, leaving the interpretation somewhat uncertain; see Neu 1968b: 117 n. 7). While it is in principle possible that these forms have been introduced by the later copyists, it is simpler to assume that they were present already in the original

value is compromised by the emergence of active inflection in the basic stem forms of historically deponent verbs during this period.

4.4 *Exceptional interactions between aspect and voice*

It was established in §4.2 that in Old and Middle Hittite unaccusative *activa tantum* consistently show voice reversal, their imperfective forms exhibiting non-active morphology in the same syntactic contexts as their basic stem forms unexpectedly show active morphology. §4.3 then demonstrated that in Old Hittite deponents show the converse voice reversal pattern, their imperfective forms exhibiting active morphology where their basic stems unexpectedly show non-active morphology. In Old Hittite, at least, there is thus a contrast between these two verbal classes and all other morphosyntactic types which, as shown in §4.1, do not undergo voice reversal. Table 7 provides a summary of the distribution of voice morphology in Old Hittite by morphosyntactic type.

SYNTACTIC TYPE	CLASS	BASIC STEM	IMPERFECTIVE
TRANSITIVE	NON-DEPONENT	ACT	ACT
	DEPONENT	NACT	ACT
UNERGATIVE	–	ACT	ACT
UNACCUSATIVE	<i>media tantum</i>	NACT	NACT
	<i>activa tantum</i>	ACT	NACT

Table 7: Distribution of voice morphology in Old Hittite.

Thus far a satisfactory synchronic explanation of voice reversal has proved elusive even for the better studied *activa tantum*; for a critique of earlier proposals see Melchert (2017: 478–9). Beyond their failure to take into account the chronological

texts, in which case they would demonstrate that verbs in *–anna/i–* are indeed compatible with non-active morphology. We therefore reject this analysis. A reviewer alternatively suggests that *–anna/i–* does not allow idiosyncratic features of the root to “transfer” across to the Voice head. This is, in fact, broadly what we propose below, though we frame it as a consequence of morphological locality. Finally, as we stated in §3.5, all imperfective suffixes are “suppletive allomorphs” of a single head (Melchert 1998: 414). It is therefore not a trivial task to make one allomorph bear idiosyncratic featural information, since, as allomorphs, they are merely distinct phonological realizations. This argues against a different reviewer’s idea that there are two syncretic aspectual suffixes pronounced *–anna/i–*, one of which is associated with idiosyncratic information. This latter solution further raises the question as to why voice reversal can be stated in terms of verb *classes*, and is not an idiosyncratic property of particular, random, roots.

distribution of forms, the central problem that faces these accounts (especially Neu 1968a: 89) is, per Inglese (2020: 184), “the lack of synchronic functional motivation of the pattern in Hittite.” This issue is starkly illustrated for the *activa tantum* by (42–43), where the active-inflected basic stem forms of *pai-* ‘go’ and *park-ešš-* ‘become tall’ occur in the same passages as their corresponding (emboldened) non-active-inflected imperfective forms. For deponent verbs the same is evident in (44), where the non-active inflected basic stem form of *parš(i)-* ‘break’ similarly cooccurs with its (emboldened) active-inflected imperfective:

- (42) *karū=ma* [ŠÀ?] É DUMU.MEŠ-*an* ***paišgahat***
 formerly=TOP inside house children.GEN.PL go.IPFV.1SG.PST.NACT
kinun=a natta kuwāpikki pāun
 now=TOP NEG anywhere go.1SG.PST.ACT
 ‘I used to go to the children’s quarters, but recently I haven’t gone anywhere.’ (KBo 17.1 iv 11–13)
- (43) *INA UD.1.KAM=ya=aš* 1 *AMMATU*
 in.one.day=CONJ=3SG.C.NOM one cubit
parkiškettari [(*INA ITU.1.KAM=ma=aš* 1
 tall.INCH.IPFV.3SG.NPST.NACT in.one.month=TOP=3SG.C.NOM 1
IKU-an)] ***parkiškattari*** ... [(*mān INA UD.15.KAM*
IKU tall.INCH.IPFV.3SG.NPST.NACT when on.fifteenth.day
ti)*yat* *n]u* NA₄ *parkišta*
 enter.3SG.PST.ACT CONN stone tall.INCH.3SG.PST.ACT
 ‘In one day **he grows** one cubit, in one month **he grows** one IKU-measure ... When the fifteenth day came, the Stone had grown tall.’ (KUB 33.93 iv 18–9, 22; *CHD P*: 160)
- (44) *nu* LUGAL-*uš* NINDA *ān* NINDA.KU₇.HI.A
 CONN king.C.NOM.SG bread warm.N.ACC.SG sweet.breads
kue *paršiya* *n=ašta* *hūma*<*n*>*daz*
 which.N.ACC.PL break.3SG.NPST.NACT CONN=PTCL all.ABL
peran arḫa tepu ***paršiannai***
 in.front away little.N.ACC.SG break.IPFV.3SG.NPST.ACT
 ‘The warm bread (and) sweet breads which the king breaks, from all (those) **he keeps breaking** off a little from the front.’ (KBo 30.69 iii 11–13)

Examples like (42–44) are striking because there is no obvious contrast between the imperfective and basic stem forms of these verbs modulo the aspectual meaning associated with the imperfective suffix. From a functional perspective, then, the voice reversal observed in these forms appears to be essentially arbitrary. Recognizing this

issue, [Melchert \(2017: 482–4\)](#) tentatively suggests a diachronic explanation for the *activa tantum*, suggesting that the voice alternations seen in Hittite *activa tantum* — i.e., basic stem forms with active inflection vs. derived *-ske-* forms with non-active inflection — was inherited from PIE. The evidence cited for this hypothesis, which comes exclusively from Tocharian, is both limited and mixed, and thus in our view insufficient to justify reconstructing the pattern.⁴³ Yet however [Melchert's](#) hypothesis is ultimately assessed, what is perhaps most relevant for the present analysis is that the Tocharian evidence does not support the possibility (suggested by a reviewer) that the Hittite suffix *-ške-* was at a diachronically earlier stage idiosyncratically associated with non-active morphology (i.e., +DEP in terms of the analysis developed in §6 below). There is therefore no historical basis for assuming that Hittite *-ške-* has any such association, which would not in any case explain why the suffix triggers “voice reversal” only in Hittite *activa tantum*. Moreover, even if [Melchert's](#) hypothesis were correct for the unaccusative *activa tantum*, the converse voice reversal pattern in deponents would still require a separate explanation.

In the next two sections, we propose a unified account of voice reversal in Hittite. Under our analysis, the fact that only *activa tantum* and deponents show voice reversal in their imperfective forms is related directly to another unique property of these verbal classes — namely, that their basic stem forms exhibit voice morphology that mismatches their syntactic context. The rationale underlying our proposal is that these mismatches are “fixed” when additional verbal morphology intervenes between the basic verb stem and inflectional endings. In other words, what appears to be “voice reversal” in imperfectives vis-à-vis their basic stem is just the emergence of syntactically expected voice morphology. However, before presenting our own analysis in §6, we first discuss previous accounts of the morphosyntax of Voice in §5.

⁴³[Melchert \(2017: 482–4\)](#) identifies five Tocharian verbs that are consistent with this pattern and two that are exceptions. In [Melchert's](#) own assessment, this evidence is “less than compelling,” and in any event, he concedes that he has no explanation for the pattern (which could in principle be explained by an analysis along the lines of ours in §6). For an alternative view of the Tocharian evidence see [Yates \(2018\)](#), who argues that non-active inflection in these unaccusative verbs is an innovation in Tocharian, the diachronic manifestation of a “dispreference for mismatches between (voice) morphology and syntax.”

5 Previous accounts and issues

Previous work addressing the relationship between voice morphology and syntax has focused especially on similar alternations in Modern Greek.⁴⁴ Like Hittite, Modern Greek displays an active/non-active split. Non-active morphology appears with (some) unaccusatives, passives, (inherent) reflexives, and deponents (Mackridge 1985; Embick 1998; 2004).⁴⁵

- (45) a. Causative:
 O Janis ekapse ti supa
 the John.NOM burnt.ACT the soup.ACC
 ‘John burnt the soup.’
- b. Anticausative:
 I supa kegete
 the soup.NOM burns.NACT
 ‘The soup is burning.’
- c. Passive:
 O Janis dolofonithike apo ton Kosta
 the John.NOM murdered.NACT by the Kostas
 ‘John was murdered by Kostas.’
- d. Reflexive:
 O Janis plithike
 the John.NOM washed.NACT
 ‘John washed.’ (Alexiadou et al. 2015: 19)
- e. Deponent:
 O Janis metahirizete to leksiko
 the John.NOM use.NACT the dictionary.ACC
 ‘John uses the dictionary.’ (Alexiadou et al. 2015: 63 n. 3)

In the influential studies of Embick (1998; 2004), Embick proposed that properties of the syntax determine the featural content of the head that realizes voice

⁴⁴See also Kallulli (2013) and Trommer (2013) on Albanian, and Grestenberger (2014a; b; 2016; 1995; 2018) on deponency in ancient Indo-European languages (in particular, Ancient Greek, Sanskrit, Latin, and Hittite).

⁴⁵Non-active morphology is also found with dispositional middles, which we leave aside here. We will assume following Lekakou (2005) that dispositional middles are derived from passives (in Modern Greek and Hittite). Note that in Ancient Greek, middle and passive forms were morphologically distinct in some tense/aspect combinations (cf. n. 3 above).

morphology, observing that the constructions where non-active morphology appears can be stated as a syntactic natural class. The central idea, that non-active morphology appears when v /Voice lacks a specifier, has been adopted in almost all subsequent theoretical work on similar systems. (We use “voice” to mean the morphological exponence, and “Voice” to mean the syntactic projection.)

- (46) Voice \leftrightarrow Voice_[NonAct] / __ No DP specifier
(Alexiadou et al. 2015: 102, adapted from Embick 1998)

Active morphology is the elsewhere case, as it does not reflect a natural class. This is meant to capture the “normal” cases of active morphology on transitives and unergatives, but also the active-marked unacusatives (our *activa tantum*). The proposal in Alexiadou & Anagnostopoulou (2004), Schäfer (2008), and Alexiadou et al. (2006; 2015) (followed by Grestenberger 2018) is that active-marked unacusatives do not merge a Voice layer at all, and so cannot introduce a [NonAct] feature. Active morphology is therefore expounded as a default. Note that this relies on voice morphology being *fusional* — what is actually being expounded is the head that realizes tense/mood and inflectional agreement features, which may or may not include a [NonAct] feature.

The situation is the opposite for deponents, because as syntactically transitive verbs, it is expected that the external argument is introduced in spec-VoiceP, and so the rule in (46) would not apply. In order to derive the non-active morphology on deponent verbs, something must be configured to allow (46) to apply. Grestenberger (2018) accordingly proposes that deponents merge a “low” subject instead of the normal position for external arguments, spec-VoiceP. This leaves spec-VoiceP empty and so the rule in (46) applies.⁴⁶ The following structures exemplify when each exponent is realized.

⁴⁶The idea behind the proposal of Grestenberger (2018: 503–9) is that diachronically deponents are derived from self-benefactives, proposed to be introduced between v P and VoiceP in an applicative phrase. Over time, the self-benefactive meaning was lost, but the structural position of such arguments was retained. See also discussion and analysis in Spathas et al. (2015).

- (47) a. Transitive verb → active morphology

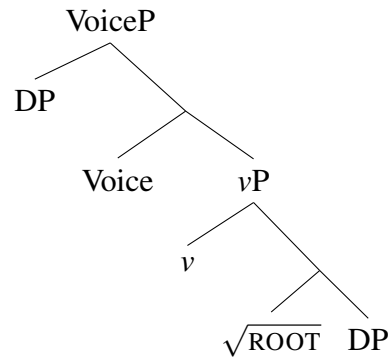

- b. Unaccusative/passive/reflexive → non-active morphology

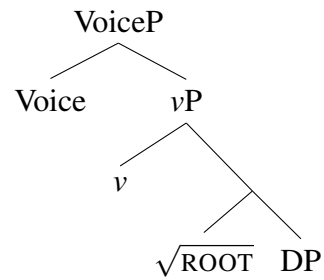

- c.
- Activa tantum*
- active morphology

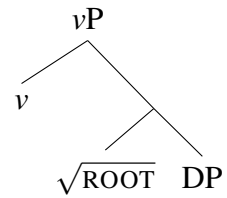

- d. Deponent → non-active morphology

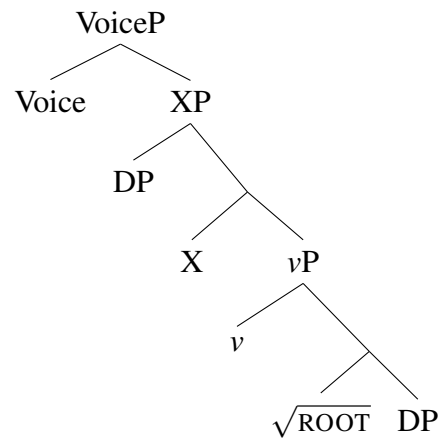

A note about the functional heads in (47) is necessary, given the various definitions for Voice and v in the literature. In the structures in (47), v is a verbalizing head which introduces an event argument, and Voice's sole job is to mitigate the presence/absence of an external argument and its thematic role. Voice and v (and later, Asp) are related via c-selection. (Not all of these assumptions are necessary on the proposals described in this section or in our own proposal, a point we return to shortly.)

Thus, structures which canonically lack an external argument in Modern Greek (i.e., unaccusatives, passives, reflexives, reciprocals) are realized using non-active voice morphology because these are structures in which Voice lacks a specifier. Additionally, deponents, argued to lack an external argument, are also subsumed by the rule in (46).⁴⁷ Unergatives and transitives will appear with active voice morphology because spec-VoiceP is filled. Deponents and *activa tantum* exhibit morphological “mismatches” because the syntax itself is configured so that (46) will or will not apply. In the former case, the transitive subject is merged in a low projection, “feeding” (46). In the latter case, Voice simply is not projected at all, “bleeding” (46). This line of analysis thus proposes to solve the issue of voice mismatch by putting the irregularity into the syntax. More precisely, *there is no mismatch between syntax and morphology*: the realization of Voice is always determined by the structural configuration.⁴⁸

It is easy to see how an account along these lines can *prima facie* cover Hittite's voice system (cf. Grestenberger 2014a: 103–5, 2018 for explicit discussion). *Activa tantum* are syntactically unaccusative and deponents are syntactically transitive; the former do not merge Voice while the latter merge a specifier-less Voice. However, it is precisely because the model proposes that the morphology of deponents and *activa tantum* is syntactically encoded that the proposal cannot extend to Hittite once the interaction with Aspect is considered. Put concisely, it is not possible to derive the voice reversals described in §4 if the deponent and *activa tantum* classes have unique structural representations.

Consider first deponents. Suppose that the subject is merged low, as in (47d). Although this class of verbs normally surfaces with non-active morphology, in the presence of Aspect active morphology appears. One possibility is that the subject stops in spec-VoiceP as it promotes to the subject position (an idea that Grestenberger 2018: 506 n. 22 considers and rejects). However, this movement must then be blocked in the absence of overt aspectual morphology, or else we expect a voice reversal in all contexts — that is, we expect there never to be deponent verbs

⁴⁷Note that inherent reflexives are assumed to be detransitivized and so will also lack an external argument.

⁴⁸A reviewer correctly points out that Embick (1998) does not adopt this view, arguing that deponents are subject to a rule identical to what is proposed in (49b).

since something will always pass through spec-VoiceP (with transitive verbs). This solution amounts to simply brute force stipulating the presence/absence of a specifier of VoiceP.

A reviewer suggests treating Asp as a “thematically raising” head (as in Ramchand 2008). Situated above VoiceP, AspP would then require the deponent subject to pass through spec-VoiceP on the way to AspP. However, this still requires massive stipulation: in the case of imperfectives of non-*activa tantum* and passives, the subject must be *prevented* from stopping in VoiceP on its way to AspP, since these verbs are realized with nonactive morphology.

Another possibility would be to try to suppress non-active voice morphology by deleting the [NonAct] feature in the presence of Aspect, i.e., impoverishment. Suppose the rule in (48) were added into the model.

(48) Voice_[NonAct] → Voice / Aspect __

This rule deletes a [NonAct] feature in the presence of an Aspect head. However, such a rule would massively over-generate, predicting that [NonAct] be deleted in all contexts in which there is aspectual morphology. Thus we would expect to see a voice reversal for *all* non-active verbs in the presence of aspect. That is, canonical unaccusatives are expected to appear with active morphology, contrary to fact. A reviewer suggests relativizing the rule in (48) to a particular setting of aspect (e.g., perfective or imperfective). Again, this over-generates. The morphological exponence of voice does not correlate with a particular aspectual category (cf, §4.1). That is, it is not the case that verbs with imperfective suffixes consistently appear with either active or non-active morphology. What we find is that only with *particular* verbal stems, the imperfective suffixes trigger a “flip” from active to non-active, or *vice versa*.

Activa tantum are likewise problematic for the analysis above. Recall that *activa tantum* display a reversal from active to non-active voice. Structurally, they are assumed to lack a Voice projection entirely in the analysis above (Alexiadou & Anagnostopoulou 2004, *i.a.*). Thus, to derive the appearance of non-active voice in the presence of Aspect, we would have to introduce a Voice projection into the structure after Aspect is merged. One way to do this is to have Voice c-select for Aspect. Voice would then be subject to the rule in (46). But for this to work, the appearance of Voice would not be subject to any thematic requirements of the root, but to the appearance of Aspect, whose distribution is independent of the selectional properties of the root.

The issue is not solved by switching the hierarchical order of Voice and Aspect (as discussed in §3.5). In this case, it would be necessary to counter-cyclically merge Voice whenever Aspect is introduced — but only for *activa tantum*, since in all other contexts, Voice is projected into the structure as a result of the lexical semantics

or idiosyncratic properties of the verb.⁴⁹ That is, we would need an algorithm to determine when Voice can and cannot be counter-cyclically introduced that is sensitive to the presence/absence of Aspect *and* the lexical class.⁵⁰

In sum, under current models of the structural representation of valency, it is not possible to derive voice reversals in Hittite voice morphology by encoding the alternation into the syntax without massively stipulating a solution or violating foundational principles of syntactic theory. The issue for the approach outlined above can be summarized concisely: because the realization of voice is tied to lexical semantic/idiosyncratic properties of the root and the addition of Aspect does not change those properties, a voice reversal cannot be derived. Given this, we believe that the solution to the problem of voice reversal must be located outside of the syntactic component. We lay out our proposal in the next section.

6 Our proposal

We understand the central issue to be one of morphological locality: when Voice appears linearly adjacent to a trigger, voice morphology may be subject to contextual allomorphy; when Voice is phonologically separated from a trigger, voice morphology is no longer subject to contextual allomorphy because the environment is not met. For this reason, it must be possible to separate the head that is realized as voice from this idiosyncratic information. This therefore entails that voice morphology is always the exponence of (the features of) a Voice head, which is subject to rules of contextual allomorphy or not. It cannot be the case that voice morphology results from the lack of a Voice head.

Keeping the main architectural assumptions from Schäfer (2008), Alexiadou et al. (2015), and Grestenberger (2018), our core proposal is that *Voice is always*

⁴⁹A reviewer thinks that this statement is on the wrong track; we respectfully disagree. On the analyses proposed in Schäfer (2008) and Alexiadou et al. (2015), whether Voice appears with unaccusatives is a function of the properties of the root. Internally caused verbs can (but need not) appear with Voice. Externally caused verbs must appear with Voice. Since these two classes can be defined in terms of the lexical semantics of the root, we believe our characterization is correct. However, even if it is not possible to independently determine which class a verb falls into, then the class information must be listed as an idiosyncratic feature of the root governing when Voice is and is not projected. This is essentially the view that Schäfer (2008: 256 n. 9) adopts.

⁵⁰Alternatively, a reviewer suggests that issues concerning counter-cyclically can be circumvented by stipulating that Aspect obligatorily c-selects for Voice, thereby requiring Voice to be present whenever Aspect is merged. However, as the reviewer concedes, we would need a way to make sure that only overt exponents of Aspect have such a c-selectional requirement, since we do not see voice reversal when Aspect is not overtly morphologically exponed. Moreover, we find this solution overly stipulative and ultimately unfalsifiable. There would be no way to independent verify that (overt) Aspect c-selects for Voice in Hittite.

projected on verbal predicates. In this we follow other authors who argue for an “expletive Voice,” such as Schäfer (2008), Alexiadou et al. (2015), and in particular Wood (2015) and Wood & Marantz (2018). Expletive Voice is a Voice head that does not introduce agentive semantics (and sometimes does not project a specifier). We return shortly to discuss why a syntactically and semantically vacuous Voice head should be merged at all. Following the authors cited above, we also assume a late insertion model of morphology, in which syntactic heads are associated with phonological form after structure building (i.e., Distributed Morphology; Halle & Marantz 1993).

Because we assume that Voice is always projected, deponents and *activa tantum* are not associated with unique syntactic trees. All diagnostically transitive verbs have an external argument in Voice. All diagnostically unaccusative verbs lack an external argument in Voice. Voice’s featural specifications may be determined by a rule such as (46), or by proximity to a morphological diacritic (i.e., a feature), triggering contextual allomorphy. We formalize this in the following way. If we assume with previous authors that active voice morphology is realized in the absence of a [NonAct] feature, then the following ordered rules derive the surface patterns. The features +DEP and +AT are class features, which stand for “is in the class of deponents/*activa tantum*,” respectively. We assume that these class features are associated with the root. Our treatment of deponents follows that of Embick (1998).

- (49) a. Voice \rightarrow Voice_{NonAct} / __ No DP specifier
 b. Voice \rightarrow Voice_{NonAct} / +DEP __
 c. Voice_{NonAct} \rightarrow Voice / +AT __

The result of the rule in (49a) is that all verbs lacking an external argument will be realized with nonactive morphology, just as Embick originally proposed. The rule in (49b) idiosyncratically inserts [NonActive] in the presence of deponent roots. The rule in (49c) likewise deletes [NonAct] in the presence of an *activa tantum* root. The rules in (49) are ordered and can feed each other as “re-write” rules. A [NonAct] feature introduced on Voice due to (49a) can be over-written by the presence of +AT in (49c). This is why *activa tantum* surface with active nonactive morphology. If the rules were “disjunctively” ordered, meaning that only rule could apply, then (49c) would never apply, since the only what Voice_{NonAct} can appear is by application of either of the two preceding rules. Similarly, if rules (49a) and (49c) swapped ordering, then (49a) could never apply because Voice_{NonAct} will not have been “made” yet. (And moreover, it would be over-written by (49c) anyway, predicting that all *activa tantum* appear with non-active morphology.)

The crucial prediction that this model makes is that in cases where Voice is not adjacent to the triggers +DEP/+AT, i.e., the environment is not met, “normal” morphology will appear. This is precisely what Hittite reveals, where the realization

of an intervening aspectual head causes voice to revert to the morphological form expected from syntactic structure. We assume that this linear ordering comes about by displacement of Voice to T, since voice morphology is fused with tense/mood morphology and appears outside of Aspect.⁵¹

(50) [[[[$\sqrt{\text{ROOT}}$] *v*] ASP] Voice+T]

In cases of deponents, the rule in (49b) cannot apply because its environment is not met. Voice is not next to the Root, and so does not have access to lexical class information. In this case, Voice will be realized as active because the rule in (49a) cannot apply either: Voice has a specifier.

Similarly for *activa tantum*, the intervening aspectual morphology prevents (49c) from applying. Thus, non-active morphology appears due to the rule in (49a). We note that the trigger +AT may not always be associated with the root, but may also appear on functional non-root material. This is apparent with the class of deadjectival inchoative verbs ending in *-ešš-*, which uniformly pattern as *activa tantum*. We understand the suffix *-ešš-* to instantiate the categorizer *v*. In this case inchoative *v* provides the trigger for allomorphy. (Expletive) Voice is merged above *v_{become}*. In contrast, the causative categorizer *-nu-*, assumed to be another “flavor” of *v* (cf. Folli & Harley 2005), is not associated with any diacritic, and so such verbs do not exhibit a voice reversal in their imperfective forms.⁵² This difference is illustrated in (51) with the adjectival root *mekk/makk-* ‘much, many’:

⁵¹We assume (without consequence) that the displacement is post-syntactic, formalized as a reordering rule, e.g., via Local Dislocation. Alternatively, we might attribute this to an effect of head-movement in the syntax, though it would require an explanation for why Asp is skipped. The apparent morphological displacement renders somewhat moot concerns about whether the aspectual heads are truly “aspect” or an event pluralizer, as discussed §3.5. We note however, that it is not necessary that the linear ordering of the exponents be derived via movement. If in fact Voice were merged above Asp, our arguments still go through because they are based on morphological locality, not structural hierarchy. We have chosen the hierarchical ordering of ASP≫VOICE≫*v* because this is, in our opinion, the “standard” sequence for an Aspectual head which is not associated with lexical aspect, but we acknowledge that it is not the only possibility. Finally, Dave Embick (p.c.) points out, intriguingly, that it may be possible to segment a voice suffix *-ri* (see Table 2). If so, then the Voice head actually appears outside of tense morphology, but the intervening tense morphology does *not* give rise to similar locality effects.

⁵²Our analysis of inchoatives and causatives is based on Alexiadou et al. (2006: 201f), Schäfer (2008); Schäfer (2017) and Sundaresan & McFadden (2017). The core idea is that Roots combine with a thematic object and then combine with an eventive *v*. This structure is standardly assumed for *v_{cause}*. The presence of Voice on top of *v_{become}* follows from the proposal in the text that Voice is always projected.

- (51) *mekk/makk-*
- ⇒ ADJ *mekk-(a)y-* ‘much, many’
[*a* [$\sqrt{\text{MEKK}}$ DP]]
 - ⇒ INCH *makk-ešš-* ‘become numerous’
[Voice [$v_{\text{become,+AT}}$ [$\sqrt{\text{MEKK}}$ DP]]]
 - ⇒ CAUS *makk-nu-* ‘make numerous’
[Voice [v_{cause} [$\sqrt{\text{MEKK}}$ DP]]]
- a. Imperfective to inchoative ⇒ voice reversal:
3SG.NPST.ACT *makkešzi* (IBoT 1.36 i 13) VS.
IPFV.3SG.IMP.NACT *makkiškattaru* (KUB 57.63 ii 41)
- b. Imperfective to causative ⇒ no voice reversal:
1SG.PST.ACT *maknunun* (KUB 31.17:5) VS.
IPFV.1SG.NPST.ACT *maknuškimi* (KUB 41.20 obv. 6)

Since the same adjective may appear with or without the voice reversal, it cannot be the case that the adjectival root bears the diacritic. Rather this information must be encoded on the verbalizing affix inchoative v .⁵³ What is relevant then is that Voice and v may be morphologically local or not, correlating with whether mismatch voice morphology appears or not. This proposal keeps the generalization that voice morphology is overall a reflection of the syntax (in that non-active voice is realized when Voice has no specifier), and it differs from previous proposals by making the mismatches stem from morphological, rather than syntactic properties.

We note that our proposal crucially relies on the assumption that null morphology does not count as a barrier for morphological locality. This is necessary because, on the assumption that an Aspect or v head is always projected into the structure, it does not inhibit the relationship between Voice and the root when Aspect/ v is phonologically null—for whatever category of aspect that is selected. Since perfective aspect is also null, it does not condition a voice reversal. This can be derived either by assuming that null morphemes are simply invisible for such operations

⁵³The verbalizing suffixes are independently required to encode class information because they also determine the verb’s conjugational class (I vs. II; cf. §3.5 above). Note further that, as pointed out by a reviewer, overt exponence of v can also have a similar effect as overt aspectual morphology. In (20), the exponence of causative *-nu-* on an otherwise *activa tantum* root may co-occur with non-active morphology. In this case, the rule in (49c) cannot apply because the local environment is not met: Voice is not linearly adjacent to the +AT trigger associated with the root. The same reviewer then wonders whether our arguments against postulating syncretic allomorphs of *-anna/i-* in n. 42 are weakened, if different flavors of v may come with idiosyncratic diacritics. But the different “flavors” of v are not allomorphs of the same head; they are distinct heads, which introduce different meanings. This is crucially different from what is discussed in n. 42, where we argue against attributing different features to true (“syncretic”) *allomorphs* of the same head.

(Embick 2010), or that such morphemes are “pruned” (Embick 2015).⁵⁴ It also renders moot whether we treat the functional heads in the verbal domain as related via c-selection, versus a functional sequence (Sundaresan & McFadden 2017). What matters is not whether a particular head is merged, nor where in the narrow syntax the head is merged. In the end, what affects the exponence of voice is whether there is *morphological locality* between the information associated on the root and Voice. If there is overt morphological material between Voice and the trigger for allomorphy, then the rules in (49b, 49c) cannot apply.

A reviewer understandably asks what the function of Voice is in this system: if Voice does not introduce a syntactic argument nor is overtly exponed, why is this not a violation of Full Interpretation (or equivalent)? A similar question arises for all other works that propose an “expletive” Voice, i.e., a Voice head that does not introduce an Agent thematic role, but is nonetheless morphologically present (Schäfer 2008; Alexiadou et al. 2015; Wood 2015; Schäfer 2017; Wood & Marantz 2018).⁵⁵ Wood (2015: 152–4) directly addresses this question. On the basis of Icelandic evidence, he proposes that Voice is always projected, whether or not it makes a thematic contribution or even has morphological exponence. He ultimately suggests that this reduces to selection: T/Asp selects for VoiceP. This proposal is meant to account for the fact that Voice is always projected in full clauses, but may be absent in reduced structures, like nominalizations.⁵⁶

⁵⁴Note though that the analysis does not depend on whether we analyze the “aspectual” suffixes as true aspect, or some other category (cf. §3.5 above). The rules are sensitive to linearized morphology, not hierarchical structure.

⁵⁵It is important to keep in mind that Schäfer (2008) and Alexiadou et al. (2015) distinguish cases of expletive Voice (which may or may not project a specifier) from not merging Voice at all. Expletive voice is found in cases of marked anticausative, while the lack of Voice is found in unmarked anticausatives. Thus in their system, the difference between marked and unmarked anticausatives is again related to which heads have been merged. Though we do not address the difference between unmarked and marked forms in this paper, our proposal would extend to languages that mark such a difference in forms by analyzing the difference as a result of morphological spell-out, rather than which heads are merged. We believe that this improves on a system which idiosyncratically merges a vacuous Voice since, as noted in Alexiadou et al. (2015: 118, n. 32), “While marked anticausatives are lexically forced to appear in the context of Voice, unmarked anticausatives do not occur with expletive Voice presumably for reasons of economy.” The problem here is that if it is *possible*, and in fact more *economical*, to not merge a semantically vacuous Voice, how can we ever *force* merge of such a head. (Schäfer 2008: 256 n. 9 suggests that it is a c-selective property of roots.) This particular problem goes away in our proposal. Whether voice morphology is pronounced reduces instead to the morphological interaction of the head Voice (always present) and the idiosyncratic information available (and visible) on the root/categorizer.

⁵⁶In our framing of the discussion, we have adopted the idea from the cited authors that Voice’s sole job is to “mitigate” an Agentive argument. But it is important to keep in mind that the external argument introducing head Voice/*v* has been proposed to provide a number of different functions, including (i) an Agent thematic relation, (ii) case, (iii) “eventivity” (i.e., issues related to inner

In fact, the correlation between higher clausal heads and the presence of Voice is further consistent with [Grestenberger’s \(2018\)](#) observation that voice mismatches disappear in some contexts. (She does not discuss the case of voice reversal in the presence of aspect observed here.) She argues that mismatches between syntax and morphology are seen only when Voice is projected into the structure. The evidence comes from non-finite forms of deponent verbs — in particular, from cases in which it can be argued that no Voice projection is available, like nominalizations and participial derivations, both of which involve a truncated clausal structure. In such cases, the mismatch goes away, and the morphology of deponents looks like the morphology of a “normal” active verb. Thus in Hittite, for instance, both deponents like *parš(i)-* ‘break’ and non-deponent transitive verbs like *epp/app-* ‘take’ use the same suffix *-ant-* to form verbal adjectives with passive readings (*parši-ant-* ‘broken’, *app-ant-* ‘taken’).⁵⁷ The system proposed above can also capture this kind of “leveling” as well: since (mismatched) voice morphology is dependent on a Voice head, and such contexts lack a Voice projection, mismatches will not occur in these contexts. If we further require that the presence of Voice can be the result of selection by a higher head, as suggested in [Wood \(2015\)](#), then these facts follow.⁵⁸

7 Conclusion

A close examination of Hittite’s active/non-active voice system reveals that irregularities in voice morphology should be attributed to the morphological rather than syntactic component. In particular, we have shown that voice reversal in Hittite — that is, cases where voice morphology flips to a form that is expected based on the external syntax — must be due to morphological locality to a trigger, rather than to properties of hierarchical structure. Our analysis provides a natural and, we believe,

aspect), and (iv) manner features ([Alexiadou & Anagnostopoulou 2004](#): 119). See also [Wood & Marantz \(2018](#): 258f) for the idea that Voice (*i in their terminology) “closes off” the extended verbal projection. It is therefore possible that Voice is required in all verbal structures for one of these purposes, and is not truly a “vacuous” projection.

⁵⁷[Grestenberger \(2018](#): 513–4) cites identical patterns in Vedic Sanskrit and Ancient Greek, where both deponents and non-deponents form passive verbal adjectives with the same suffixes (Ved. *-tá-*, AGk. *-tó-*). Likewise, [Grestenberger \(2018](#): 495–6) discusses agent noun formation in Vedic, Ancient and Modern Greek, and Latin, observing that deponent and non-deponent verbal stems use the same morphology (e.g., Lat. *horta-tor* ‘inciter’ \Leftarrow deponent *hortor*, ‘urge, incite’; *amā-tor* ‘lover’ \Leftarrow non-deponent *amō* ‘love’). On our view, all such forms follow because deponents are syntactically identical to non-deponents.

⁵⁸In fact, it is not clear if [Grestenberger’s \(2018\)](#) system (or ours) predicts no mismatches in the absence of Voice. There is nothing built into the system that would prevent some other affix from being sensitive to a diacritic property of a root/categorizer in the absence of Voice. The point we are making is that our system covers [Grestenberger’s](#) data as well.

intuitive approach to the relationship between voice morphology and syntax. To the extent that Hittite is representative of active/non-active voice systems in general, the proposal can straightforwardly be extended to the data in Embick (1998; 2004), Schäfer (2008), Alexiadou et al. (2015), and Grestenberger (1995; 2018). However, our study raises a pressing question for future work: there is variation among the Indo-European languages as to whether intervening affixes give rise to similar voice reversals. For instance, Latin famously does not exhibit a voice reversal for deponents when voice morphology appears outside of intervening tense/aspect morphology. Thus, e.g., in (52) the deponent verb *hortor* ‘urge, exhort’ shows non-active morphology in the basic form of its imperfective stem in (52a) and also when the past tense-marking (traditionally, “imperfect”) suffix *-bā-* intervenes in (52b) (cf. Embick 2000: 191, 197).

- (52) a. *senex in culīnā clāma-t, hortā-tur*
 old.man.NOM.SG in kitchen.ABL.SG shout-3SG.ACT urge-3SG.PASS
coquōs
 cook.ACC.PL
 ‘The old man is shouting in the kitchen and urging on the cooks.’ (Plaut. *Cas.* 764)
- b. *sed coquōs, quasi in marī sole-t hortātor*
 but cook.ACC.PL like in sea.ABL be.wont-3SG.ACT urger.NOM.SG
rēmigēs hortā-rier, ita hortā-bā-tur
 oarsman.ACC.PL urge-INF.PASS, thus urge-PST-3SG.PASS
 ‘But as for the cooks, he was urging them on, like a steersman (lit. ‘urger’) is in the habit of urging on oarsmen at sea.’ (Plaut. *Merc.* 695–7; cf. Grestenberger 2018: 492)

It is therefore an open question which intervening morphemes disrupt the locality relation, which do not, and why. We are hopeful that a broader consideration of the patterns may shed light on similar intervention effects, and in turn, on ways in which morphology is and is not sensitive to (non-)local information.

Still, we believe that our study correctly situates syntactic and morphological processes into the appropriate places in the grammar. All things being equal, we expect that there are universal exceptionless rules that govern syntax, i.e., Agents are merged in spec-VoiceP (or equivalent) and Patients are merged as complements to V (or equivalent). We also expect the morphological component to introduce irregularity, e.g., English past tense morphology. Our study confirms these independent defining characteristic properties of syntax and morphology. We do not need to introduce irregularity into the rules that govern argument structure when it can be attributed to the morphological component.

Acknowledgments

We are grateful to David Embick, Teigo Onishi, Brent Vine, and especially Craig Melchert for extensive comments and critical discussion, as well as to Guglielmo Inglese and Simone Mattioli for sharing preliminary versions of their work. We owe thanks, too, to audiences at the 3rd Munich-UCLA Historical Linguistics Colloquium (especially Olav Hackstein), and at the 93rd Annual Meeting of the Linguistic Society of America, where earlier versions of this work were presented. Finally, we thank four anonymous *Glossa* reviewers for their comments, which have made this a better paper. Naturally, any remaining errors are our own.

References

- Alexiadou, Artemis & Elena Anagnostopoulou. 2004. Voice Morphology in the Causative-Inchoative Alternation: Evidence for a Non-Unified Structural Analysis of Unaccusatives. In Artemis Alexiadou, Elena Anagnostopoulou & Martin Everaert (eds.), *The Unaccusativity Puzzle*, 114–136. Oxford / New York: Oxford University Press.
- Alexiadou, Artemis, Elena Anagnostopoulou & Florian Schäfer. 2006. The properties of anticausatives crosslinguistically. In Mara Frascarelli (ed.), *Phases of Interpretation*, 187–212. Berlin / New York: de Gruyter.
- Alexiadou, Artemis, Elena Anagnostopoulou & Florian Schafer. 2015. *External Arguments in Transitivity Alternations*. Oxford / New York: Oxford University Press.
- Bechtel, George. 1936. *Hittite Verbs in –sk–: A Study of Verbal Aspect*. Ann Arbor: Edwards Brothers.
- Boley, Jacqueline. 1984. *The hittite ḫark-construction*. Innsbruck: Institut für Sprachwissenschaft der Universität Innsbruck.
- Boley, Jacqueline. 1992. The Hittite Periphrastic Constructions. In Onofrio Carruba (ed.), *Per una Grammatica Ittita – Towards a Hittite Grammar*, 35–59. Pavia: Gianni Iuculano.
- Boley, Jacqueline. 1993. *The Hittite Particle –z/–za*. Innsbruck: Institut für Sprachwissenschaft der Universität Innsbruck.
- Cambi, Valentina. 2007. *Tempo e aspetto in Ittito: Con particolare riferimento al suffisso –ske/a–*. Alessandria: Edizioni dell’Orso.
- Cambi, Valentina & Pier Marco Bertinetto. 2006. Hittite temporal adverbials and the aspectual interpretation of the –ske/a-suffix. In Raffaella Bombi, Guido Cifoletti, Lucia Innocente & Vincenzo Orioles (eds.), *Studi linguistici offerti in onore di roberto gusmani*, 193–233. Alessandria: Edizioni dell’Orso.

- Cotticelli-Kurras, Paola. 1991. *Das Hethitische Verbum 'sein': Syntaktische Untersuchungen*. Heidelberg: Winter.
- Cotticelli-Kurras, Paola. 1992. Die hethitischen Nominalsätze. In Onofrio Carruba (ed.), *Per una Grammatica Ittita – Towards a Hittite Grammar*, 99–135. Pavia: Gianni Iuculano.
- Cotticelli-Kurras, Paola. 2015. Periphrastic constructions, phasal verbs, and Aktionsart in Hittite. *InVerbis* 1. 43–61.
- Cotticelli-Kurras, Paola & Alfredo Rizza. 2011. Die hethitische partikel –z(a) im licht neuer theoretischer ansätze. In Thomas Krisch & Thomas Lindner (eds.), *Indogermanistik und Linguistik im Dialog: Akten der XIII. Fachtagung der Indogermanischen Gesellschaft vom 21. bis 27. September 2008 im Salzburg*, 12–30. Wiesbaden: Reichert.
- Cotticelli-Kurras, Paola & Alfredo Rizza. 2013. Reconstructing Proto-Indo-European Categories: The Reflexive and the Middle in Hittite and the Proto-language. *Journal of Historical Linguistics* 3(1). 7–27.
- Cusic, David D. 1981. *Verbal Plurality and Aspect*: Stanford University dissertation.
- Dardano, Paola. 2005. I costrutti perifrastici con il verb *ḫar(k)*– dell-ittito: stato della questione e prospettive di metodo. *Orientalia* 74. 93–113.
- Dardano, Paola. 2006. *Die hethitischen Tontafelkataloge aus Ḫattuša (CTH 276–282)*. Wiesbaden: Harrassowitz.
- Daes, Alexandra. 2009. Zum Funktionsbereich des Suffixes –*ške/o*– im Junghethitischen und Homerischen. In Rosemarie Lühr & Sabine Ziegler (eds.), *Protolanguage and Prehistory: Akten der XII. Fachtagung der Indogermanischen Gesellschaft, vom 11. bis 15. Oktober 2004 in Krakau*, 82–99. Wiesbaden: Reichert.
- Daes, Alexandra. 2010. Zur Korrelation der hethitischen Konjunktion *kuitman* mit dem Verbalsuffix –*ške*–. In Ronald Kim, Norbert Oettinger, Elizabeth Rieken & Michael Weiss (eds.), *Ex Anatolia Lux: Anatolian and Indo-European Studies in honor of H. Craig Melchert on the Occasion of his Sixty-Fifth Birthday*, 9–18. Ann Arbor, MI / New York: Beech Stave Press.
- Daes, Alexandra. 2012. The Hittite Verbs in –*šša*–: Can a Function be Recognized? In H. Craig Melchert (ed.), *The Indo-European Verb: Proceedings of the Conference of the Society for Indo-European Studies, Los Angeles 13-15 September 2010*, 29–41. Reichert.
- Dempsey, Timothy R. 2015. *Verbal reduplication in anatolian*: University of California, Los Angeles dissertation.
- Dressler, Wolfgang. 1968. *Studien zur verbalen Pluralität*. Wien: Böhlau.
- Embick, David. 1998. Voice systems and the syntax/morphology interface. In Heidi Harley (ed.), *Papers from the UPenn/MIT Roundtable on Argument Structure and Aspect*. 41–72. Cambridge, MA.

- Embick, David. 2000. Features, syntax, and categories in the Latin Perfect. *Linguistic Inquiry* 31(2). 185–230.
- Embick, David. 2004. Unaccusative syntax and verbal alternations. In Artemis Alexiadou, Elena Anagnostopoulou & Martin Everaert (eds.), *The Unaccusativity Puzzle*, 137–158. Oxford / New York: Oxford University Press.
- Embick, David. 2010. *Localism versus Globalism in Morphology and Phonology*. Cambridge, MA: M.I.T. Press.
- Embick, David. 2015. *The Morpheme: A Theoretical Introduction*. Berlin / New York: de Gruyter.
- Flobert, Pierre. 1975. *Les verbes déponents latins des origines à charlemagne*. Paris: Belles Lettres.
- Folli, Raffaella & Heidi Harley. 2005. Flavours of *v*: Consuming results in Italian and English. In P. Kempchinsky & R. Šlabakova (eds.), *Aspectual inquiries*, 95–120. Dordrecht: Kluwer.
- Friedrich, Johannes, Annelies Kammenhuber & Inge Hoffmann. 1975–. *Hethitisches Wörterbuch*. Heidelberg: Winter 2nd edn.
- Frotscher, Michael. 2013. *Das hethitische –ant–partizip und seine indogermanischen Grundlagen: Semantik, Morphologie, Syntax*: University of Verona dissertation.
- Garrett, Andrew. 1990a. Hittite Enclitic Subjects and Transitive Verbs. *Journal of Cuneiform Studies* 42(2). 227–242.
- Garrett, Andrew. 1990b. *The Syntax of Anatolian Pronominal Clitics*: Harvard University dissertation.
- Garrett, Andrew. 1996. Wackernagel’s Law and Unaccusativity in Hittite. In Aaron Halpern & Arnold M. Zwicky (eds.), *Approaching Second: Second Position Clitics and Related Phenomena*, chap. Chicago, 85–133. University of Chicago Press.
- Goetze, Albrecht. 1933. *Die Annalen des Muršiliš*. Leipzig: Hinrichs.
- Grestenberger, Laura. 1995. More span-conditioned allomorphy: Voice morphology in Classical Greek. In Christopher Hammerly & Brandon Pickett (eds.), *Proceedings of the 46th Annual Meeting of the North East Linguistics Society*, 47–61. Amherst, MA: University of Massachusetts Graduate Linguistic Student Association.
- Grestenberger, Laura. 2014a. *Feature Mismatch: Deponency in Indo-European Languages*: Harvard University dissertation.
- Grestenberger, Laura. 2014b. “split Deponency” in Proto-Indo-European. In Stephanie W. Jamison, H. Craig Melchert & Brent Vine (eds.), *Proceedings of the 25th Annual UCLA Indo-European Conference*, 75–84. Bremen: Hempen.
- Grestenberger, Laura. 2016. Reconstructing Proto-Indo-European Deponents. *Indo-European Linguistics* 4. 98–149.

- Grestenberger, Laura. 2018. Deponency in finite and non-finite contexts. *Language* 94(3). 487–526.
- Grestenberger, Laura. 2019. Deponency in morphology. In *Oxford Research Encyclopedia in Linguistics*, Oxford / New York: Oxford University Press.
- Güterbock, Hans G., Harry A. Hoffner & Theo van den Hout (eds.). 1989–. *The Hittite Dictionary of the Oriental Institute of Chicago*. Chicago: The Oriental Institute of the University of Chicago.
- Halle, Morris & Alec Marantz. 1993. Distributed Morphology and the Pieces of Inflection. In *The View from Building 20: Essays in Linguistics in Honor of Sylvain Bromberger*, 111–176. Cambridge, MA: M.I.T. Press.
- Haspelmath, Martin. 1993. More on the typology of inchoative/causative verb alternations. In Bernard Comrie & Maria Polinsky (eds.), *Causatives and Transitivity*, 87–120. Amsterdam / Philadelphia: John Benjamins.
- Haspelmath, Martin. 2016. Universals of causative and anticausative verb formation and the spontaneity scale. *Lingua Posnaniensis* LVIII(2). 33–63. <https://doi.org/10.1515/linpo-2016-0009>.
- Hoffner, Harry A. 1997. *The Laws of the Hittites: A Critical Edition*. Leiden/New York: Brill.
- Hoffner, Harry A. 1998. On the Denominative Verb *arāwe-*. In Jay H. Jasanoff, H. Craig Melchert & Lisi Oliver (eds.), *Mír Curad: Studies in Honor of Calvert Watkins*, 275–283. Innsbruck: Institut für Sprachwissenschaft der Universität Innsbruck.
- Hoffner, Harry A. & H. Craig Melchert. 2002. A Practical Approach to Verbal Aspect in Hittite. In Stefano de Martino & Franca Pecchioli Daddi (eds.), *Anatolia Antica: Studi in Memoria di Fiorella Imparati*, 377–390. Firenze: Eothen.
- Hoffner, Harry A. & H. Craig Melchert. 2008. *A Grammar of the Hittite Language. Vol. I: Reference Grammar*. Winona Lake, IN: Eisenbrauns.
- Hofmann, Johann B. 1910. *De verbis quae in prisca latinitate extant deponentibus commentatio*. Greifswald: Abel.
- Houwink ten Cate, Philo H.J. 1970. *The Records of the Early Hittite Empire (c. 1450–1380 bce)*. Istanbul: Nederlands Historisch-Archaeologisch Instituut in het Nabije Oosten.
- Inglese, Guglielmo. 2020. *The Hittite Middle Voice: Synchrony, Diachrony, Typology*. Leiden / Boston: Brill.
- Inglese, Guglielmo & Silvia Luraghi. 2020. The Hittite Periphrastic Perfect. In Robert Crellin & Thomas Jügel (eds.), *Perfects in Indo-European Languages and Beyond*, 337–410. Amsterdam / Philadelphia: John Benjamins.
- Inglese, Guglielmo & Simone Mattioli. to appear. Pluractionality in Hittite: A New Look at the Suffix *-ške/a-*. *Sprachtypologie und Universalienforschung* .

- Kallulli, Dalina. 2013. (non-)canonical passives and reflexives: Deponents and their like. In Artemis Alexiadou & Florian Schäfer (eds.), *Non-canonical Passives*, 337–358. Amsterdam / Philadelphia: John Benjamins.
- Kammenhuber, Annelies. 1961. *Hippologia Hethitica*. Wiesbaden: Harrassowitz.
- Kemmer, Suzanne. 1993. *The Middle Voice*. Amsterdam / Philadelphia: John Benjamins.
- Kloekhorst, Alwin. 2008. *Etymological Dictionary of the Hittite Inherited Lexicon*. Leiden / Boston: Brill.
- Laca, Brenda. 2002. Spanish ‘aspectual’ periphrases: Ordering constraints and the distinction between situation and viewpoint aspect. In Javier Gutiérrez-Rexach (ed.), *From Words to Discourse: Trends in Spanish Semantics and Pragmatics*, 61–93. Oxford: Elsevier.
- Laca, Brenda. 2004a. Progressives, pluractionals, and the domains of aspect. In Olivier Crouzet, Hamida Demirdache & Sophie Wauquier (eds.), *Domaines: Proceedings of the Journée de Linguistique de Nantes 2004*, 87–92.
- Laca, Brenda. 2004b. Romance ‘aspectual’ periphrases: Eventuality modification versus ‘syntactic’ aspect. In Jacqueline Guéron & Jacqueline Lecarme (eds.), *The Syntax of Time*, 425–440. Cambridge, MA: M.I.T. Press.
- Laca, Brenda. 2006. Indefinites, quantifiers, and pluractionals: What scope effects tell us about event pluralities. In Svetlana Vogeleer & Liliane Tasmowski (eds.), *Non-definiteness and Plurality*, 191–217. Amsterdam / Philadelphia: John Benjamins.
- Lekakou, Maria. 2005. *In the Middle, Somewhat Elevated*: University of London dissertation.
- Levin, Beth & Malka Rappaport-Hovav. 1995. *Unaccusativity: At the Syntax-Lexical Semantic Interface*. MIT press.
- Luraghi, Silvia. 1992. I verbi in *-nu-* e il loro valore causativo. In Onofrio Carruba (ed.), *Per una Grammatica Ittita – Towards a Hittite Grammar*, 153–180. Pavia: Gianni Iuculano.
- Luraghi, Silvia. 2010. Transitivity, intransitivity and diathesis in Hittite. *Indo-European Linguistics and Classical Philology* 16(2). 133–154.
- Luraghi, Silvia. 2012. Basic valency orientation and the middle voice in Hittite. *Studies in Language* 36(1). 1–32.
- MacDonald, Jonathan E. 2008. *The Syntactic Nature of Inner Aspect: A Minimalist Perspective*. Amsterdam / Philadelphia: John Benjamins.
- Mackridge, Peter. 1985. *The Modern Greek Language*. Oxford University Press.
- Mattiola, Simone. 2019. *Typology of Pluractional Constructions in the Languages of the World*. Amsterdam / Philadelphia: John Benjamins.
- Melchert, H. Craig. 1984. *Studies in Hittite Historical Phonology*. Göttingen: Vandenhöck & Ruprecht.

- Melchert, H. Craig. 1998. Aspects of Verbal Aspect in Hittite. In *Acts of the IIIrd International Congress of Hittitology, Çorum, 16–22 september 1996*. 413–418. Ankara.
- Melchert, H. Craig. 2017. Mediopassives in *-ské/o- to Active Intransitives. In Ivo Hajnal, Daniel Kölligan & Katharina Zipser (eds.), *Miscellanea Indogermanica. Festschrift für José Luis García Ramón zum 65. Geburtstag*, 477–486. Innsbruck: Institut für Sprachen und Literaturen der Universität Innsbruck.
- Melchert, H. Craig. to appear. The Medio-Passive in Transition from Old to New Hittite. In a forthcoming Festschrift.
- Neu, Erich. 1968a. *Das hethitische Mediopassiv und seine indogermanischen Grundlagen*. Wiesbaden: Harrassowitz.
- Neu, Erich. 1968b. *Interpretation der hethitischen mediopassiven Verbalformen*. Wiesbaden: Harrassowitz.
- Neu, Erich. 1980. *Althethitische Ritualtexte im Umschrift*. Wiesbaden: Harrassowitz.
- Oettinger, Norbert. 2019. Zum Verhältnis von Medium und Aktiv im Hethitischen und seiner Vorgeschichte. In Adam A. Catt, Ronald I. Kim & Brent Vine (eds.), *QAZZU warrai: Anatolian and Indo-European Studies in Honor of Kazuhiko Yoshida*, 267–278. Ann Arbor / New York: Beech Stave Press.
- Pinkster, Harm. 2015. *The Oxford Latin Syntax. Volume I: The Simple Clause*. Oxford / New York: Oxford University Press.
- Puhvel, Jaan. 1984. *Hittite Etymological Dictionary, Vol. 2: Words beginning with E and I*. Berlin / New York: Mouton.
- Puhvel, Jaan. 1991a. *Hittite Etymological Dictionary, Vol. 3: Words beginning with H*. Berlin / New York: de Gruyter.
- Puhvel, Jaan. 1991b. *Homer and Hittite*. Innsbruck: Institut für Sprachwissenschaft der Universität Innsbruck.
- Ramchand, Gillian Catriona. 2008. *Verb Meaning and the Lexicon* (Cambridge Studies in Linguistics 116). Cambridge University Press.
- Rix, Helmut & Martin J. Kümmel (eds.). 2001. *Lexikon der indogermanischen Verben: Die Wurzeln und ihre Primärstambildungen*. Wiesbaden: Reichert 2nd edn.
- Schäfer, Florian. 2008. *The Syntax of (Anti-)Causatives*. Amsterdam / Philadelphia: John Benjamins.
- Schäfer, Florian. 2017. Romance and Greek medio-passives and the typology of voice. In Roberta D'Alessandro, Irene Franco & Ángel J. Gallego (eds.), *The Verbal Domain*, 129–152. Oxford and New York: Oxford University Press.
- Schultze-Berndt, Eva. 2012. Pluractional Posing as Progressive: A Construction between Lexical and Grammatical Aspect. *Australian Journal of Linguistics* 32(1). 7–39.
- Shatskov, Andrey. 2018. *Hittite Nasal Presents*: Leiden University dissertation.

- Smith, Carlota S. 1991. *The Parameter of Aspect*. Dordrecht / Boston: Kluwer.
- Spathas, Giorgos, Artemis Alexiadou & Florian Schäfer. 2015. Middle Voice and reflexive interpretations: *afto*-prefixation in Greek. *Natural Language & Linguistic Theory* 33. 1293–1350.
- Strauß, Rita. 2006. *Reinigungsrituale aus Kizzuwatna: Ein Beitrag zur Erforschung hethitischer Ritualtradition und Kulturgeschichte*. Berlin / New York: de Gruyter.
- Sundaresan, Sandya & Thomas McFadden. 2017. The articulated *v* later: evidence from Tamil. In Roberta D'Alessandro, Irene Franco & Ángel J. Gallego (eds.), *The Verbal Domain*, 153–178. Oxford and New York: Oxford University Press.
- Tenny, Carol Lee. 1987. *Grammaticalizing Aspect and Affectedness*: Massachusetts Institute of Technology dissertation.
- Travis, Lisa. 2010. *Inner Aspect: The Articulation of the VP*. Dordrecht: Springer.
- Trommer, Jochen. 2013. Stress Uniformity in Albanian. *Linguistic Inquiry* 44(1). 109–143.
- van Geenhoven, Veerle. 2004. *for*-Adverbials, Frequentativity, and Plurationality. *Natural Language Semantics* 12(2). 135–190.
- van Geenhoven, Veerle. 2005. Atelicity, pluractionality, and adverbial quantification. In Henk Verkuyl, Henriette de Swart & Angeliek van Hout (eds.), *Perspectives on Aspect*, 107–124. Dordrecht: Springer.
- Watkins, Calvert. 1968–9. The Celtic Masculine and Neuter Enclitic Pronouns. *Études Celtiques* 12. 92–95.
- Watkins, Calvert. 1969. *Geschichte der indogermanischen Verbalflexion (Indogermanische Grammatik: III/1, Formenlehre)*. Heidelberg: Winter.
- Watkins, Calvert. 1971. Hittite and Indo-European Studies: The Denominative Statives in **-ē-*. *Transactions of the Philological Society* 70(1). 51–93.
- Weisser, Phillip. 2014. Mismatch verbs: A unified account of unaccusatives and deponents. In Franz Rainer, Francesco Gardani, Hans C. Luschützky & Wolfgang U. Dressler (eds.), *Morphology and Meaning: Selected Papers from the 15th International Morphology Meeting, Vienna, February 2012*, Amsterdam / Philadelphia: John Benjamins.
- Wood, Jim. 2015. *Icelandic Morphosyntax and Argument Structure*. Dordrecht: Springer.
- Wood, Jim & Alec Marantz. 2018. The interpretation of external arguments. In Roberta D'Alessandro, Irene Franco & Ángel J. Gallego (eds.), *The Verbal Domain*, 255–278. Oxford University Press.
- Yates, Anthony D. 2015. Anatolian Default Accentuation and its Diachronic Consequences. *Indo-European Linguistics* 3. 145–187.
- Yates, Anthony D. 2017. *Lexical Accent in Cupeño, Hittite, and Indo-European*: University of California, Los Angeles dissertation.

- Yates, Anthony D. 2018. Voice mismatch in Hittite: Locality and emergent alignment. Paper presented at the 3rd Munich-UCLA Historical Linguistics Colloquium, Munich, 26 July 2018 (Handout available at: <http://www.adyates.com/research/>).
- Yates, Anthony D. & Sam Zukoff. 2018. The Phonology of Anatolian Reduplication: Synchrony and Diachrony. *Indo-European Linguistics* 6. 201–270.
- Zombolou, Katerina & Artemis Alexiadou. 2014. The canonical function of the deponent verbs in Modern Greek. In Franz Rainer, Francesco Gardani, Hans C. Luschütsky & Wolfgang U. Dressler (eds.), *Morphology and Meaning: Selected Papers from the 15th International Morphology Meeting, Vienna, February 2012*. 331–344.